



b Physics Prospects For The LHCb Experiment



Thomas Ruf
for the LHCb Collaboration



- Introduction
- Detector Status
- Physics Program

Primary goal of the LHCb Experiment

- Search for New Physics contributions in Loop diagrams, e.g.

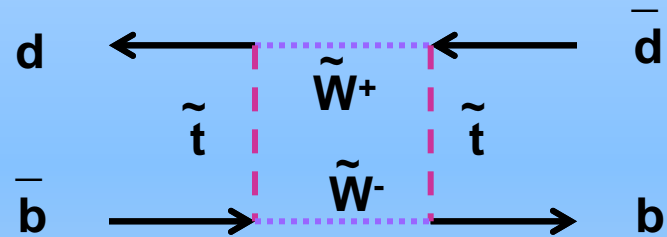
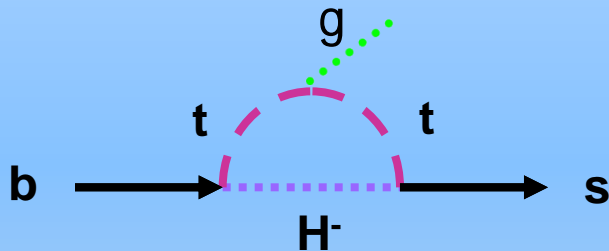

- New phases give naturally rise to new sources of CP violation
- Provides complementary information to direct production of new particles which will help to pin down the nature of New Physics
- Depends only weakly on the energy range of the accelerator

Why B decays ?

- SM contributions are in many places small and under control
new physics makes a visible impact
or strong constrains on new physics can be set
- B-mesons can be produced in large quantities

What LHC has to offer

- Protons, $7 \leftrightarrow 7$ TeV
- Visible cross section: ~ 63 mb
- b cross section: ~ 0.5 mb
- $B_d/B_u/B_s/B_c/b$ -baryons
4 : 4 : 1 : 0.01 : 1
- Ultimate luminosity of LHC: $10^{34} \text{cm}^{-2}\text{s}^{-1}$
 - ▶ > 20 interactions / x-ing
- LHCb prefers: $(2-3) \cdot 10^{32} \text{cm}^{-2}\text{s}^{-1}$
 - ▶ Mainly single interactions
 - ▶ Still 10^5 b-hadrons per second
 - ▶ Luminosity is tunable by adjusting beam focus
($0.05 < \dots < 1$) (ATLAS/CMS)

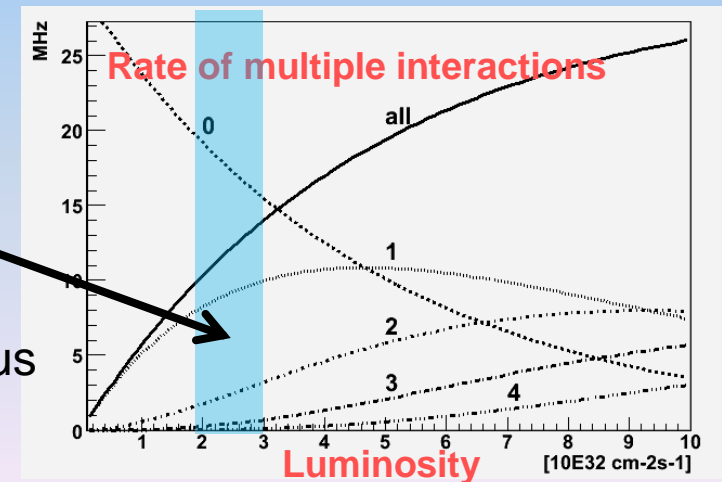
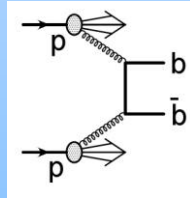

b-production at LHC

- Large boost a forward single arm spectrometer can cover a large fraction of the phasespace

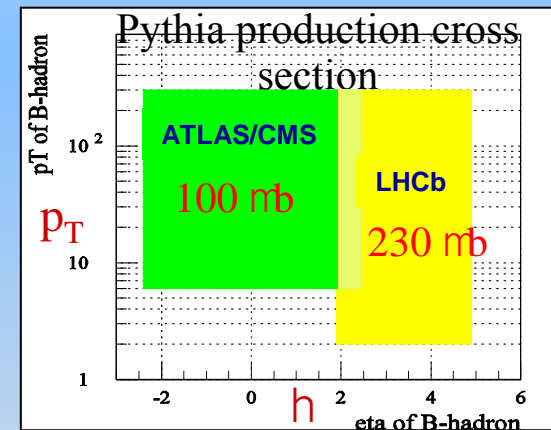
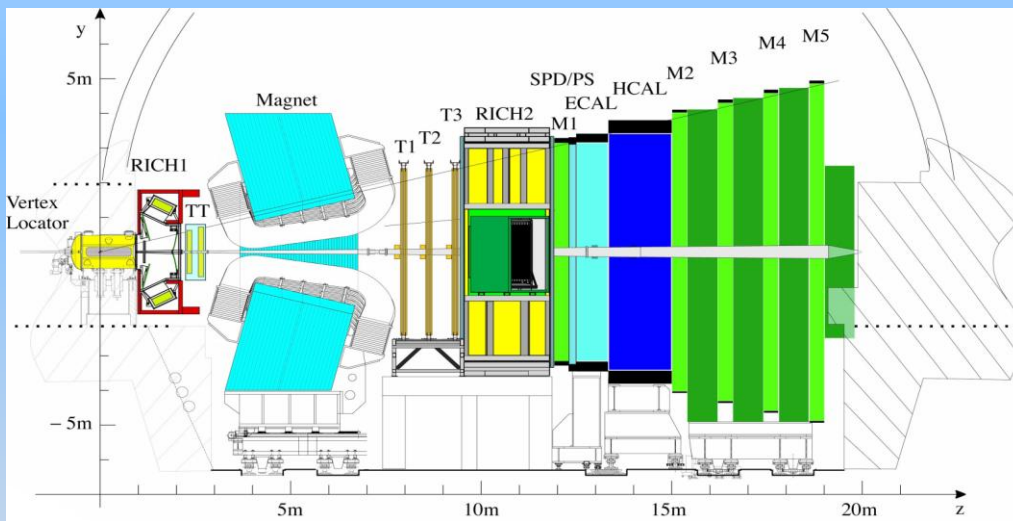

- b and \bar{b} fly in the same direction

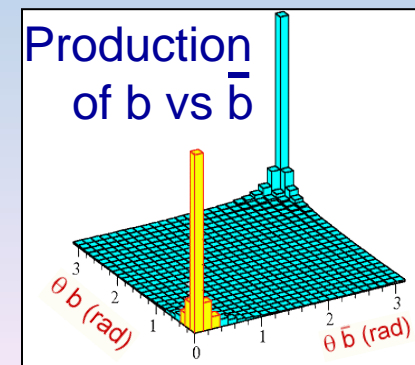



LHCb Collaboration

- 657 people, 47 Institutes, 14 countries

<http://LHCb.cern.ch>



Detector Requirements

Key for success

- ▶ High precision tracking close to the production vertex
- ▶ Lepton identification and K/p separation over a large momentum range
- ▶ High selective trigger, efficient and flexible

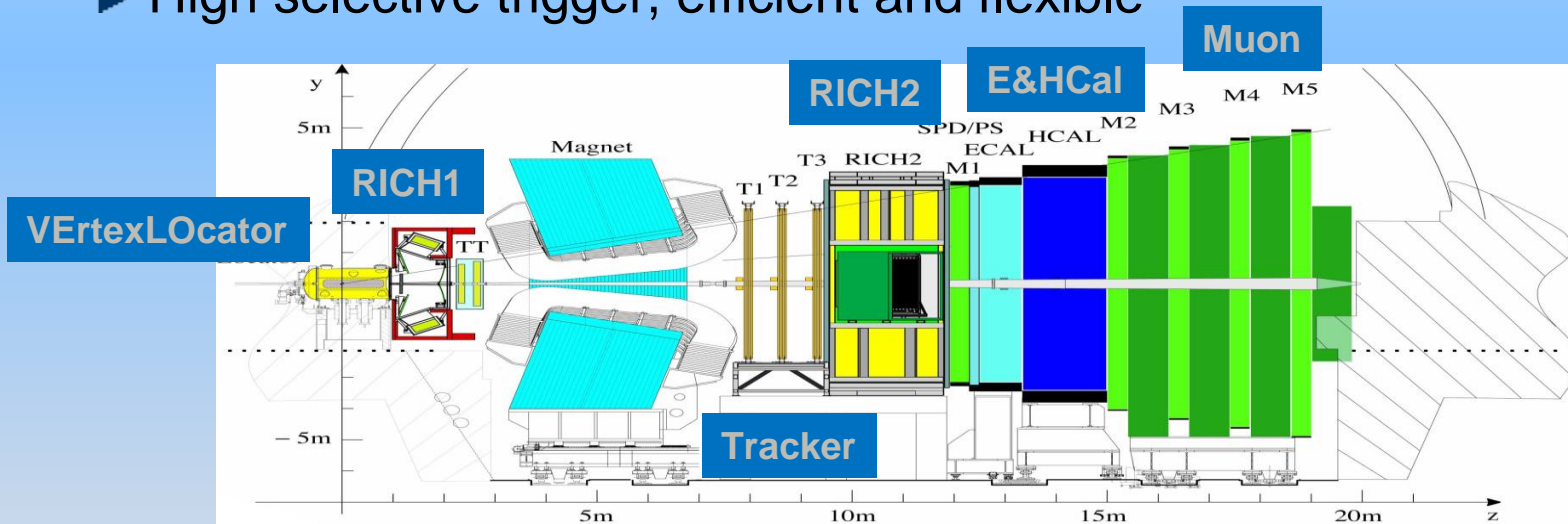

Required a long-term R&D to find optimal solution for a hadron collider

- ▶ Some examples ⇒

Tracking and vertex reconstruction in vacuum

- ▶ Silicon strip detectors with r-phi geometry for fast online track reconstruction
- ▶ 42 modules, 7mm from beam, with 250mm Al foil between detector and beam vacuum
- ▶ Designed for radiation hardness
- ▶ Detector moves in and out for LHC injection

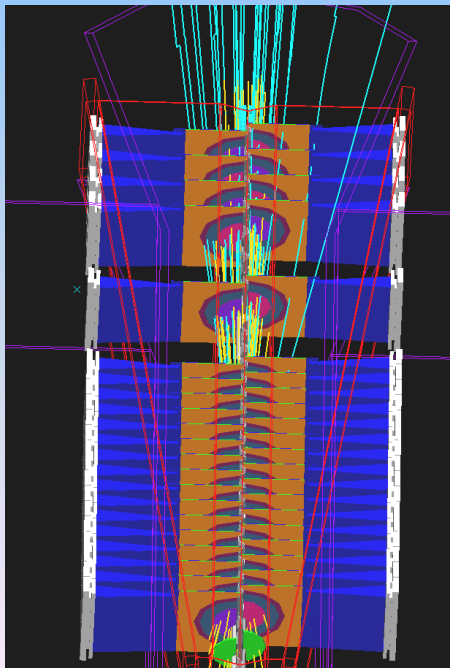
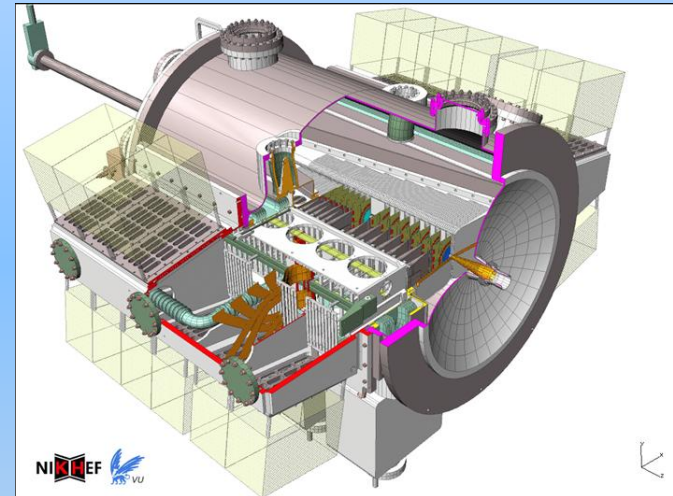

Thomas Ruf

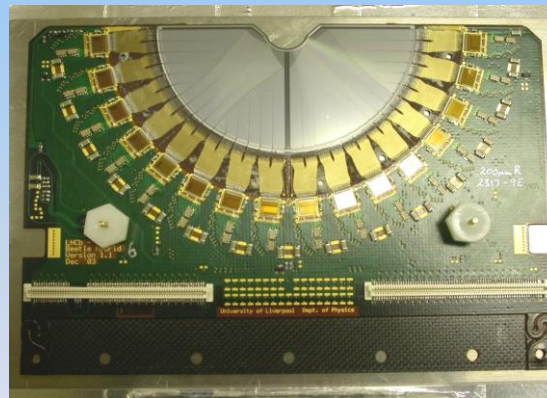

Hybrid Photo Detectors (HPD)

- ▶ Novel technology: Photocathodes with Silicon pixel readout
- ▶ ~ 200-600 nm
- ▶ ~500 tubes for two RICH detectors
- ▶ ρ -K separation from 2-100 GeV/c using three different radiators

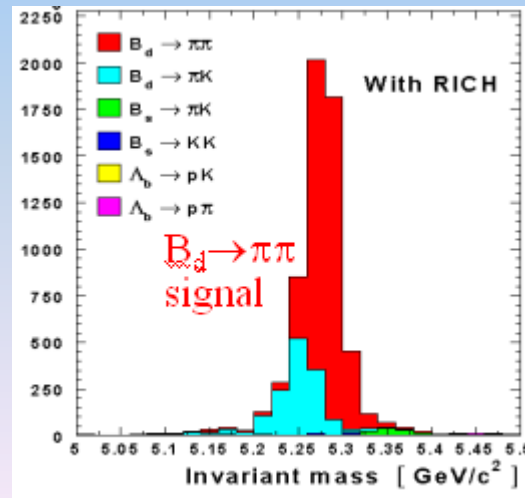
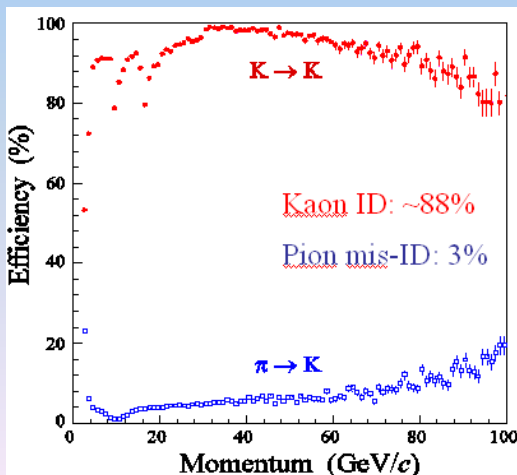
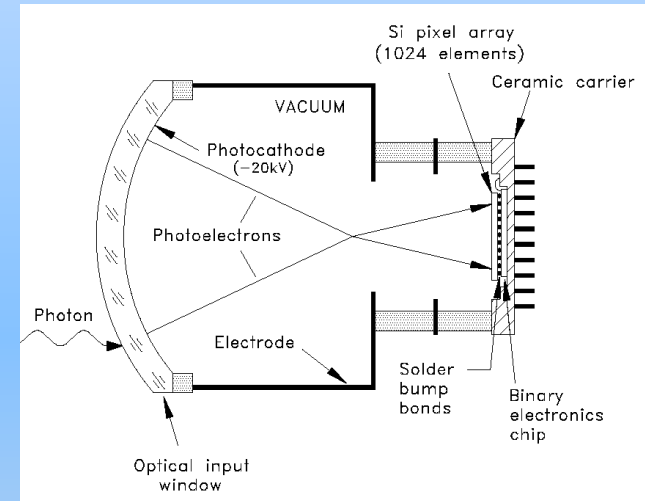

■ Trigger, Two Major Trigger Levels

- ▶ L0: Hardware
 - Objects: muon, ecal, hcal
 - Require “high” $p_t / E_t > (1-4) \text{ GeV}/c$
 - Fixed latency: 4ns
 - Input rate: 40MHz, output rate: 1MHz
- ▶ HLT: Software, running on large processor farm (~2000 units)
 - Latency depends on N(units)
 - All detector information available, usage depends on execution time
 - Start from L0 objects, reconstruct tracks in Velo to get primary vertices, find more high p_t tracks to confirm b/decay topology
 - Reject events as soon as possible

■ Typical efficiencies

- ▶ L0:
 - ~50% for hadronic channels
 - ~70% for radiative channels
 - ~85% for mchannels
- ▶ HLT:
 - ~(80 -100)%

■ DAQ

- ▶ Digitization and zero suppression on custom built boards
- ▶ After L0, data send at 1MHz from the subdetectors through a large switch, ~50 GB/s, to the event filter farm

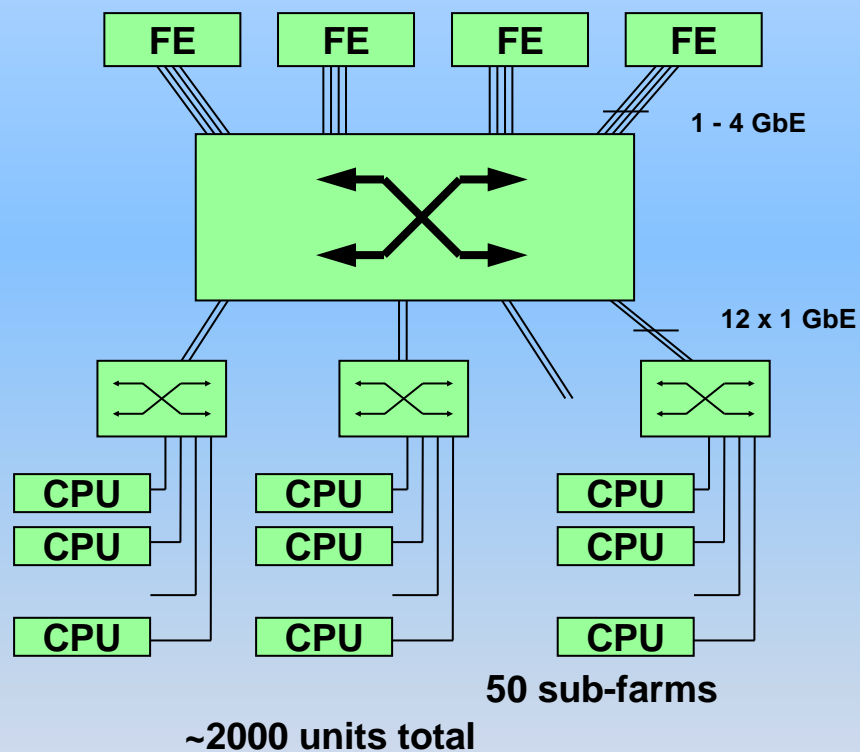

- ▶ Average output rate to storage 2kHz = 80MB/s

Detector Installation Status

- Installation started 2004 with the Dipole Magnet
- Now, in full swing. Expected to be finished for start of global commissioning in Spring 2007
- Installed
 - ▶ Magnet, ECAL, HCAL, Muon Filter, RICH2, Velo Vacuum Vessel, PreShower

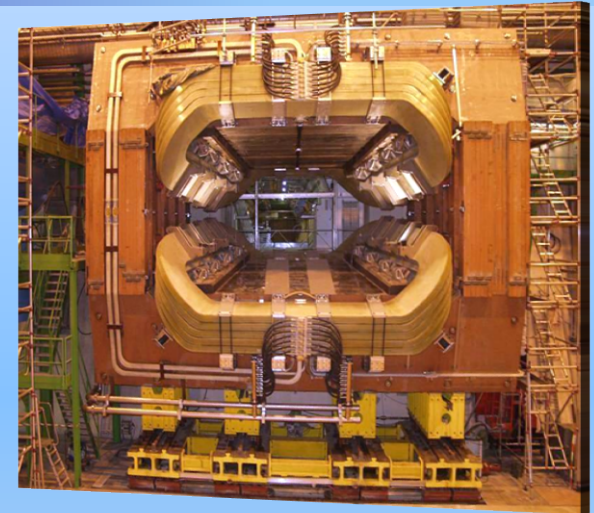

Detector Installation Status, cont.

■ Remaining parts to be installed until end of this year

- ▶ Outer tracker, underway, all modules built
- ▶ Muon chambers 1277/1450 build
- ▶ Silicon Tracker, ~30% modules built

■ Offline

- ▶ Computing challenge DC06
- ▶ Final reconstruction software being setup, Alignment&Calibration challenge end 06

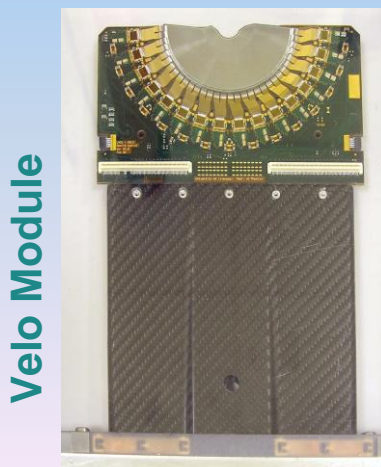
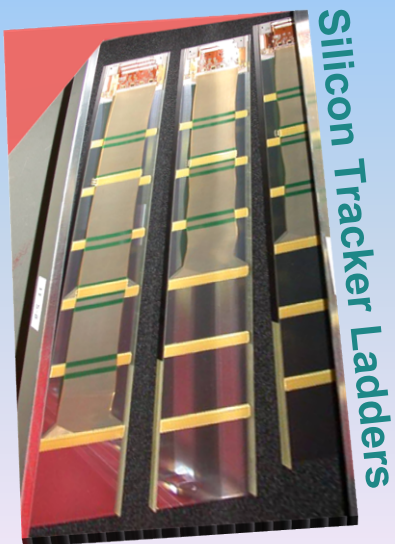

■ LHC pilot run in 2007

- ▶ Detector calibration
- ▶ First Alignment with tracks

- Precise measurements of B_d and B_s mixing, Δm and
- CKM angle measurements
 - ▶ α from $B_s \rightarrow D_s K$ combined with CP in $B_s \rightarrow J/\psi f$
 - ▶ β from $B \rightarrow D^0 K$ and $B^0 \rightarrow D^0 K^{*0}$
 - ▶ α using $B \rightarrow \pi\pi$ and $B^0 \rightarrow \pi\rho$
 - ▶ β at high accuracy
- Penguin decays
 - ▶ $B^0 \rightarrow K^{*0} \pi^0, B_s \rightarrow f \pi^0$
 - ▶ $B^0 \rightarrow K^{*0} \pi^0$
- Very Rare decays
 - ▶ $B_{s(d)} \rightarrow \pi^0 \pi^0$
- Charm Physics: D^0 mixing, CP violation
- + ... Non exhaustive list !

LHCb Physics Studies are based on full GEANT4 MonteCarlo simulations including all known detector effects, material, noise, x-talk, spillover.

Currently preparing final reconstruction software, to be exercised extensively before data taking.

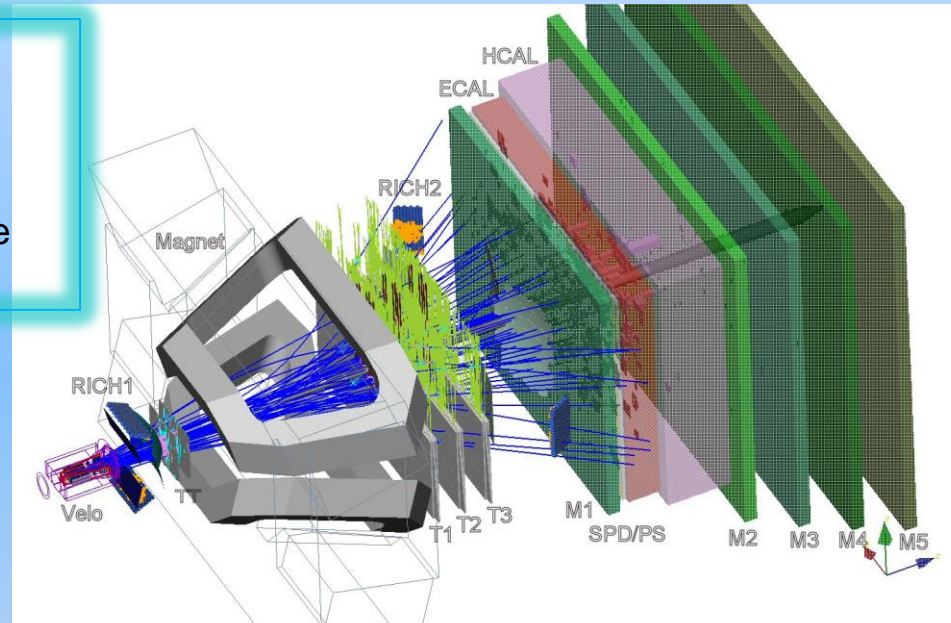

- ▶ Track efficiency $\sim 95\%$, ghost rate $\sim 5\%$
- ▶ Momentum resolution $p/p \sim 0.4\%$
- ▶ Impact Parameter resolution $S_{IP} \sim 20$ mm for high- p_t tracks
- ▶ B-Mass resolutions depending on final state topology $10\text{-}60$ MeV/ c^2
- ▶ Typical Lifetime resolution $\sim 40\text{-}60$ fs
- ▶ Flavour Tagging:
 - $B_s : eD^2 \sim 7.5\%$
 - $B_d : eD^2 \sim 4.3\%$

Measurements of g

Three main methods:

- Time dependent decay asymmetries in $B_s \rightarrow D_s K$ combined with $B_s \rightarrow J/\psi F$:
 $S(g) = 14-15^\circ$, annual yield 5.4k, $B/S < 1$

- Time dependent decay asymmetries in $B^0 \rightarrow \rho^+ \rho^-$ together with $B_s \rightarrow K^+ K^-$ and assuming U-spin symmetry:
 $S(g) = 4-6^\circ$, annual yield 26 (37)k, $B/S < 0.7 (=0.3)$

- 6 Time integrated and self tagged rates of $B^0 \rightarrow D^0 K^{*0}$, $B^0 \rightarrow D^{\sim 0} K^{*0}$ and $B^0 \rightarrow D_{CP} K^{*0}$:
 $S(g) = 7-8^\circ$, annual yield 3.4k, 0.5k, 0.6k, $B/S < 0.5, < 2.9, < 2.9$

annual yield == $2fb^{-1}$

No new Physics expected here

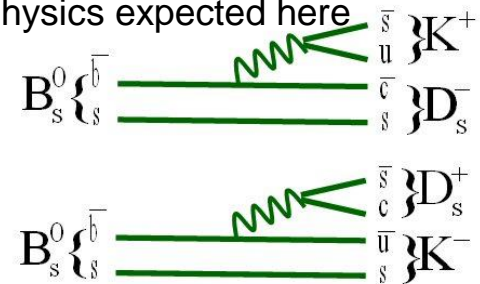

Could expect large new Physics here

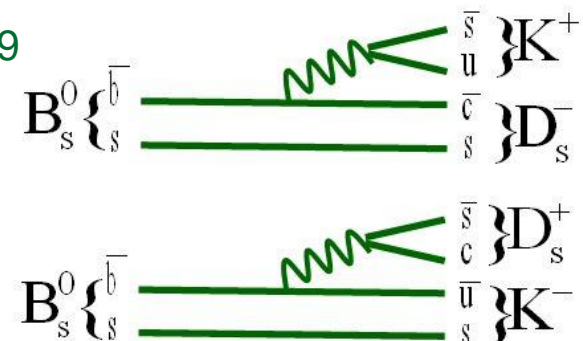
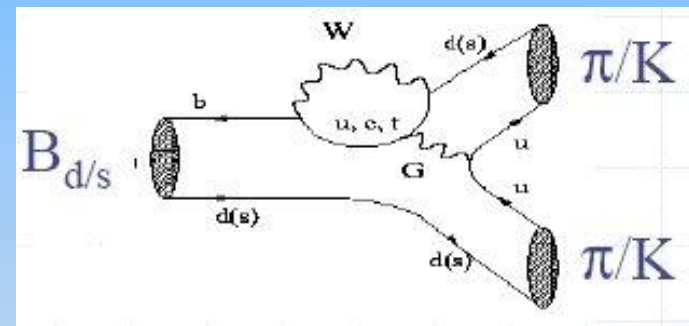

CP Asymmetry in $B_S \rightarrow J/\psi f$

- Counterpart to $B^0 \rightarrow J/\psi K_S$, measures CPV phase f_S in B_S mixing
- Requires angular analysis due to vector/vector final state
- Expect for 2 fb^{-1} about 130k events with $B/S=0.12$. Projected errors are (for $m_S = 20 \text{ ps}^{-1}$):
 - 0.02 in f_S
 - 0.009 in s'/s

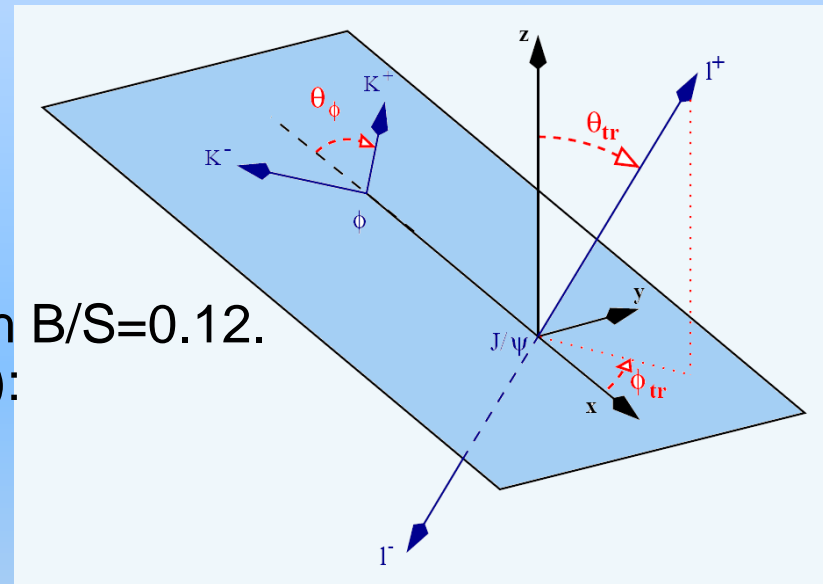

- Including $B_S \rightarrow J/\psi h$ (h_c) and $B_S \rightarrow h_c f$, CP even only, but larger background, increases slightly sensitivity (14k events)

- **Sensitive probe for SUSY:**
 $\text{Br}(B_s \rightarrow \mu\mu) \sim 5 \times 10^{-7} \left(\frac{\tan \beta}{50} \right)^6 \left(\frac{300 \text{ GeV}}{M_A} \right)^4$
- **Standard Model expectation: $\sim 3.5 \times 10^{-9}$**
- **Main concern: Background suppression**
- **Outcome of detailed MC studies**
 - ▶ m_τ -misidentification probability = $\sim 1.5\%$
 - ▶ Background mainly combinatorics from $b \rightarrow \mu X$ and $b \rightarrow \mu X$
 - ▶ $B/S < 5.7$, estimate limited by MC statistics
 - $B \rightarrow \mu\mu$ background $\sim 1.1 \times 10^{-9}$
 - ▶ ~ 17 SM-events expected in one nominal year

Forward-backward Asymmetry in $K^* \mu \mu$

- Forward-backward asymmetry $A_{FB}(s)$ in the m rest-frame is sensitive to all kind of new particles

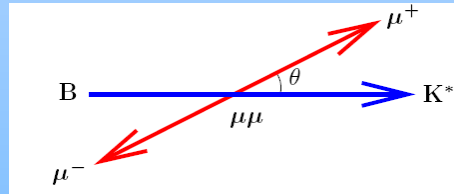

- 4400 reconstructed events / 2 fb^{-1} , $S/B > 0.4$

- Zero crossing point located with 0.5 GeV^2 for 10 fb^{-1}

Typical Measurement:

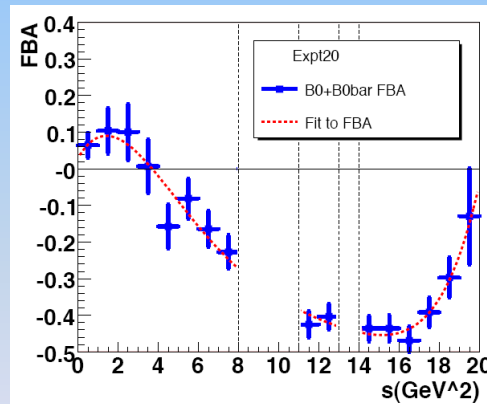

- Determines $C_7^{\text{eff}}/C_9^{\text{eff}}$ with 13% error

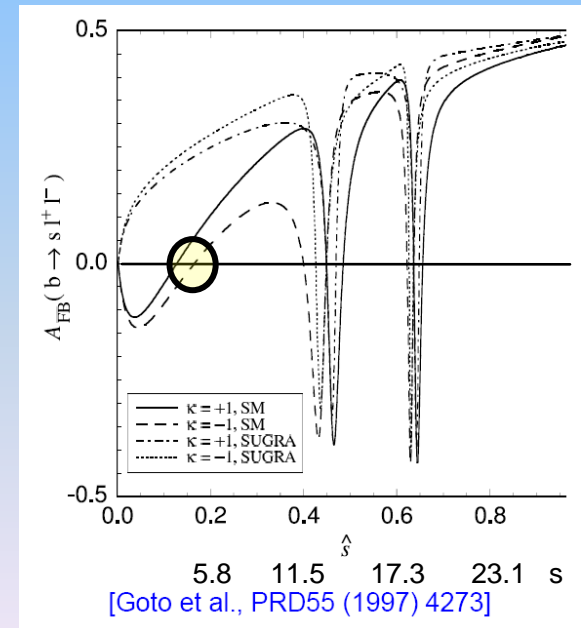
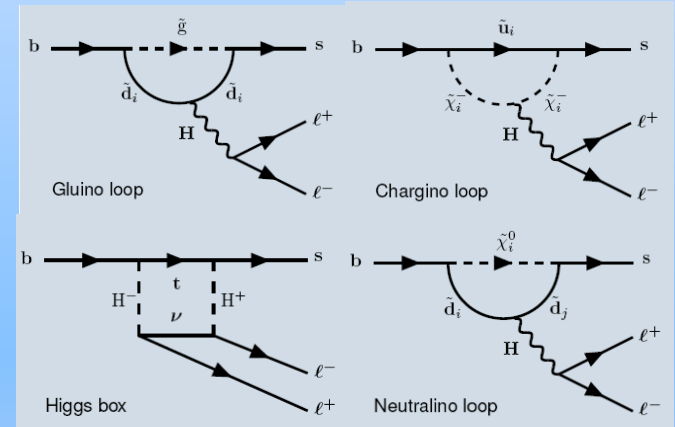

Summary of Physics Sensitivities

Only subset of modes, for 2 fb^{-1} :

	Det. eff. (%)	Tot. eff. (%)	Vis. BR (10^6)	Annual signal yield	B/S from bb bkg.	Parameter	Error	
$B^0 \rightarrow p \bar{p}$	12.2	0.69	4.8	26k	< 0.7	g	6°	U-spin symmetry
$B_s \rightarrow K^+ K^-$	12.0	0.99	18.5	37k	0.3			
$B_s \rightarrow D_s^+ K^-$	5.4	0.27	10.	5.4k	< 1.0	g	14°	
$B^0 \rightarrow D^{*0}(K^+ p) K^{*0}$	5.3	0.35	1.2	3.4k	< 0.5	g	8°	
$B^0 \rightarrow J/\psi K_s^0$	6.4	1.26	20.	216k	0.8	b	0.9°	
$B_s \rightarrow J/\psi f$	7.5	1.45	31.	131k	0.12	F_s	1.2°	
$B^0 \rightarrow \rho^+ p^-$	6.0	0.07	20.	14k	< 1.0	a	$< 10^\circ_{\text{stat}}$	
$B^0 \rightarrow K^{*0} g$	9.5	0.16	29.	35k	< 0.7	A_{DIR}	$< 1\%$	Zero x-ing 10fb^{-1}
$B^0 \rightarrow K^{*0} m^+ m^-$			0.8	4.4k	< 2.5	A_{FB}	$0.5\text{GeV}/c^2$	
$B_s \rightarrow D_s^+ \rho^-$	5.4	0.34	120.	80k	0.3	m_s	68ps^{-1}	reach
$B_s \rightarrow m^+ m^-$		2.4	0.0035	17	< 5.7	BR	$< 10^{-8}$	

For charm:

- 500 million D^* $\rightarrow \rho D^0(K^+ p)$, mixing sensitivity: $s_y = 2 \times 10^{-4}$, $s_x = 4 \times 10^{-3}$
- 50 million D^* $\rightarrow \rho D^0(K^+ K^-)$, CP asymmetry: statistical precision = 1.4×10^{-4}

Summary

- LHCb will be ready for the LHC pilot run in 2007.
- Detector and reconstruction expected to be calibrated and tuned for the Physics Run in 2008.
- LHCb will take-over the torch from the B-factories and CDF&D0 in 2008/9 to continue the success of b-physics.
- LHC delivers a large amount of b-hadrons, the experiments have to make best use of them.

