

$$\phi_2/\alpha$$

Flavor Physics & CP Violation

2006/04/09

Chin-chi Wang
National Taiwan University



C.C.Wang

Flavor Physics & CP Violation

April 9-12, 2006 : Vancouver, B.C., Canada



Outline

- Introduction.
 - What is ϕ_2/α .
 - Isospin analysis.
- Measurement of ϕ_2/α from B factory.
 - $B^0 \rightarrow \pi^+ \pi^-$
 - $B^0 \rightarrow \rho^+ \rho^-$
 - $B^0 \rightarrow \pi^+ \pi^- \pi^0 (\rho^\pm \pi^\mp)$
- Summary of ϕ_2/α measurement.



Introduction

$$V_{CKM} = \begin{pmatrix} V_{ud} & V_{us} & V_{ub} \\ V_{cd} & V_{cs} & V_{cb} \\ V_{td} & V_{ts} & V_{tb} \end{pmatrix} \sim \begin{pmatrix} 1 - \lambda^2/2 & \lambda & A\lambda^3(\rho - i\eta) \\ -\lambda & 1 - \lambda^2/2 & A\lambda^2 \\ A\lambda^3(1 - \rho - i\eta) & -A\lambda^2 & 1 \end{pmatrix}$$

where A, λ, ρ, η are Wolfenstein parameters

From unitarity ($V_{CKM}^* V_{CKM} = 1$):

$$\begin{pmatrix} d' \\ s' \\ b' \end{pmatrix} = V_{CKM} \begin{pmatrix} d \\ s \\ b \end{pmatrix}$$

$$V_{ud}V_{ub}^* + V_{cd}V_{cb}^* + V_{td}V_{tb}^* = 0$$

The Unitarity Triangle

- $\phi_1 \leftrightarrow \beta$
- $\phi_2 \leftrightarrow \alpha$
- $\phi_3 \leftrightarrow \gamma$

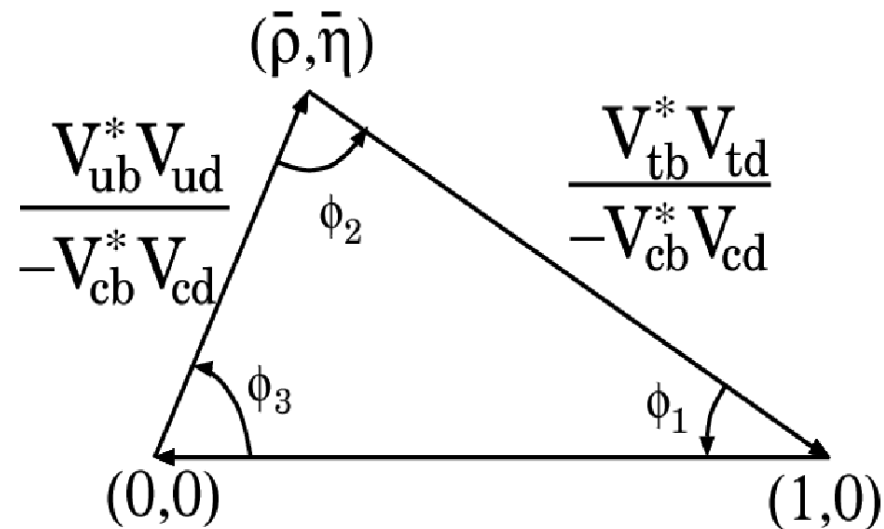



Introduction

$$B^0 \rightarrow \pi^+ \pi^-$$

$$B^0 \rightarrow \rho^+ \rho^-$$

$$B^0 \rightarrow \rho^\pm \pi^\mp$$

Tree diagram

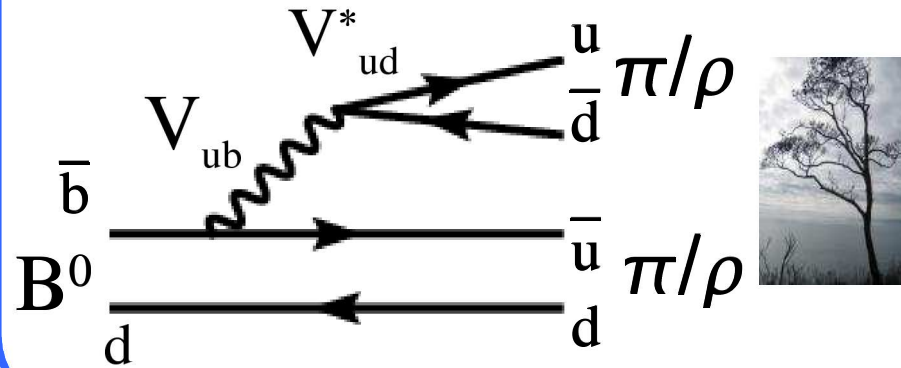

ϕ_2

Mixing

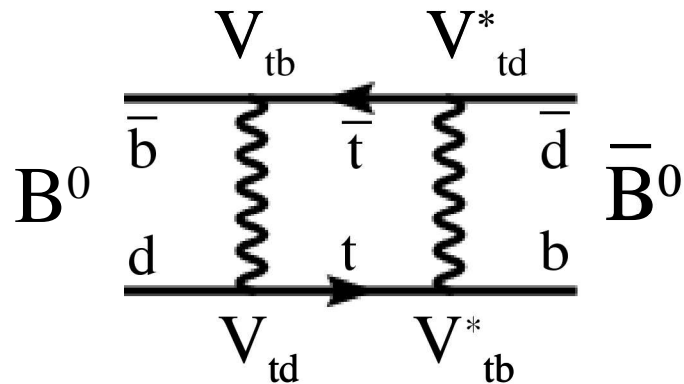

Penguin diagram

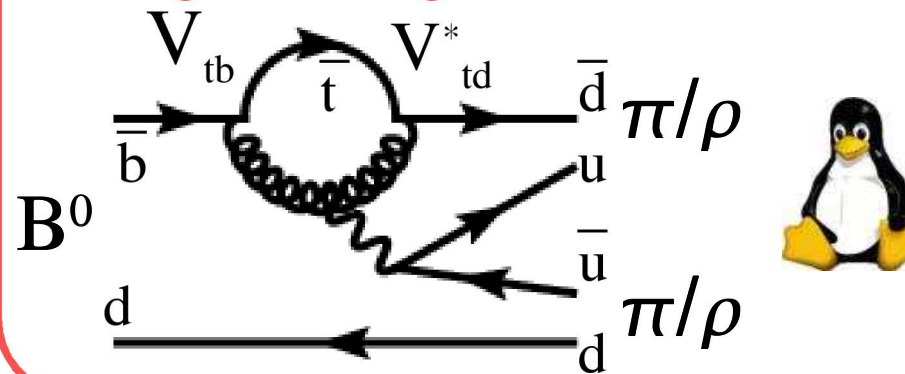

0



Isospin Analysis

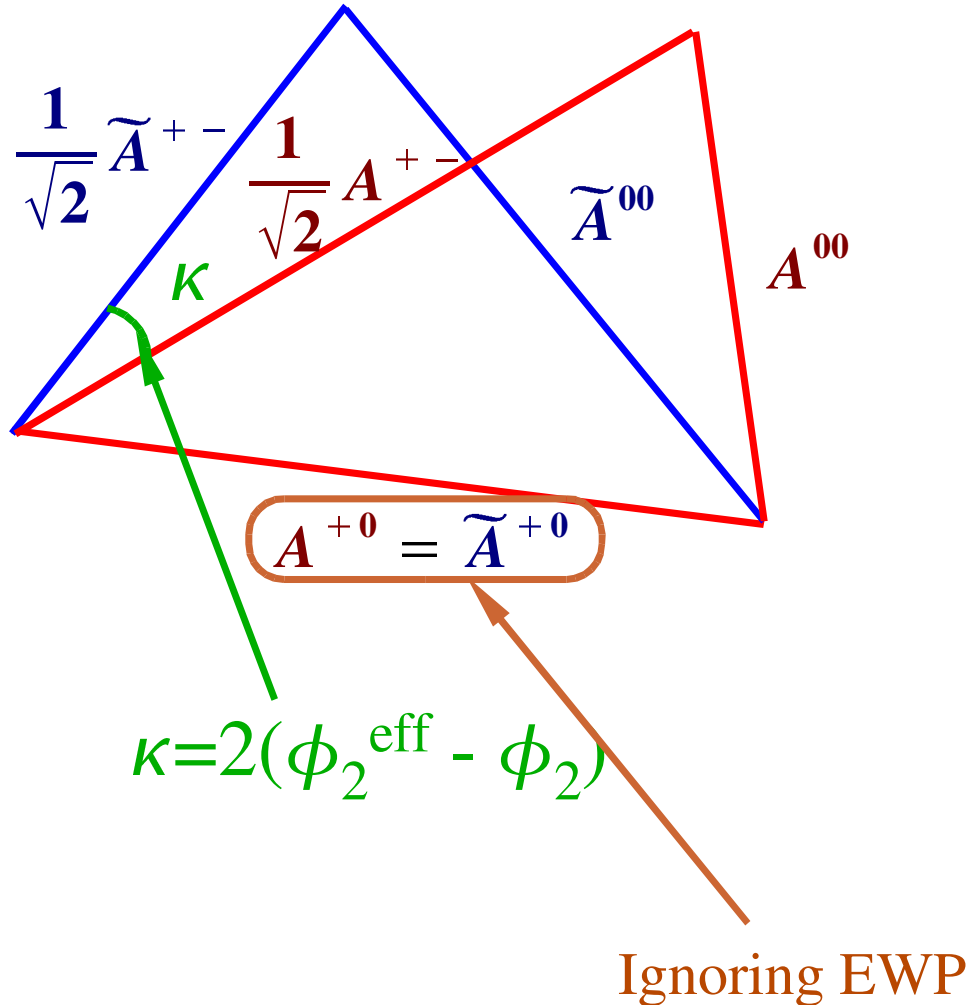

$$A^{+-} = A(B^0 \rightarrow \pi^+ \pi^- / \rho^+ \rho^-)$$

$$A^{+0} = A(B^+ \rightarrow \pi^+ \pi^0 / \rho^+ \rho^0)$$

$$A^{00} = A(B^0 \rightarrow \pi^0 \pi^0 / \rho^0 \rho^0)$$

$$\tilde{A}^{+-} = e^{2i\phi_3} \bar{A}(B^0 \rightarrow \pi^+ \pi^- / \rho^+ \rho^-)$$

$$\tilde{A}^{+0} = e^{2i\phi_3} A(B^- \rightarrow \pi^- \pi^0 / \rho^- \rho^0)$$

$$\tilde{A}^{00} = e^{2i\phi_3} \bar{A}(B^0 \rightarrow \pi^0 \pi^0 / \rho^0 \rho^0)$$



CPV measurement of $B^0 \rightarrow \pi^+ \pi^-$

Prospects for ϕ_2/α extraction:

- Good point
 - all charged track
 - good background suppression.
- Bad (difficult) points
 - large branching fraction from $B \rightarrow \pi^0 \pi^0$
 - large penguin contribution.



CPV measurement of $B^0 \rightarrow \pi^+ \pi^-$

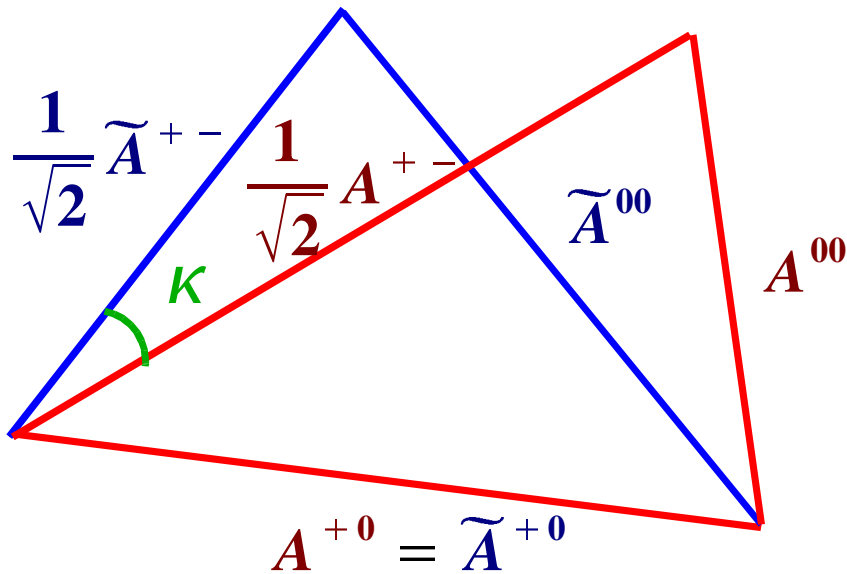

Inputs

$$\text{Br}(B^+ \rightarrow \pi^+ \pi^0) = (5.5 \pm 0.6) \times 10^{-6}$$

$$\text{Br}(B^0 \rightarrow \pi^+ \pi^-) = (5.0 \pm 0.4) \times 10^{-6}$$

$$\text{Br}(B^0 \rightarrow \pi^0 \pi^0) = (1.5 \pm 0.3) \times 10^{-6}$$

$$A(B^0 \rightarrow \pi^0 \pi^0) = +0.28 \pm 0.4$$

$$S(B^0 \rightarrow \pi^+ \pi^-) = -0.50 \pm 0.12$$

$$A(B^0 \rightarrow \pi^+ \pi^-) = +0.37 \pm 0.10$$



$B^0 \rightarrow \pi^+ \pi^-$ CPV measurement at Belle

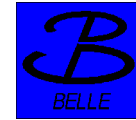

253 fb⁻¹

PRL 95, 101801 (2005)

$$\mathcal{A}_{\pi\pi} = +0.56 \pm 0.12 \pm 0.06$$

$$\mathcal{S}_{\pi\pi} = -0.67 \pm 0.16 \pm 0.06$$

4 σ evidence of Direct CPV!

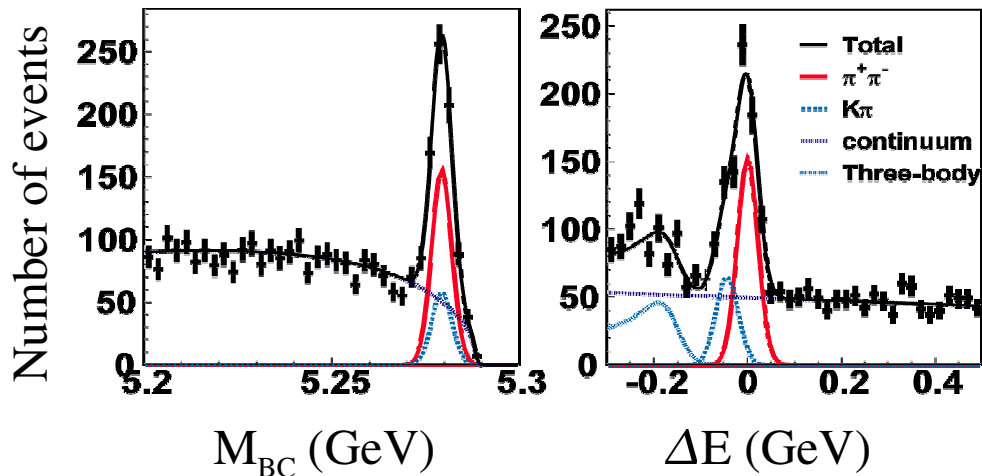

High Quality region

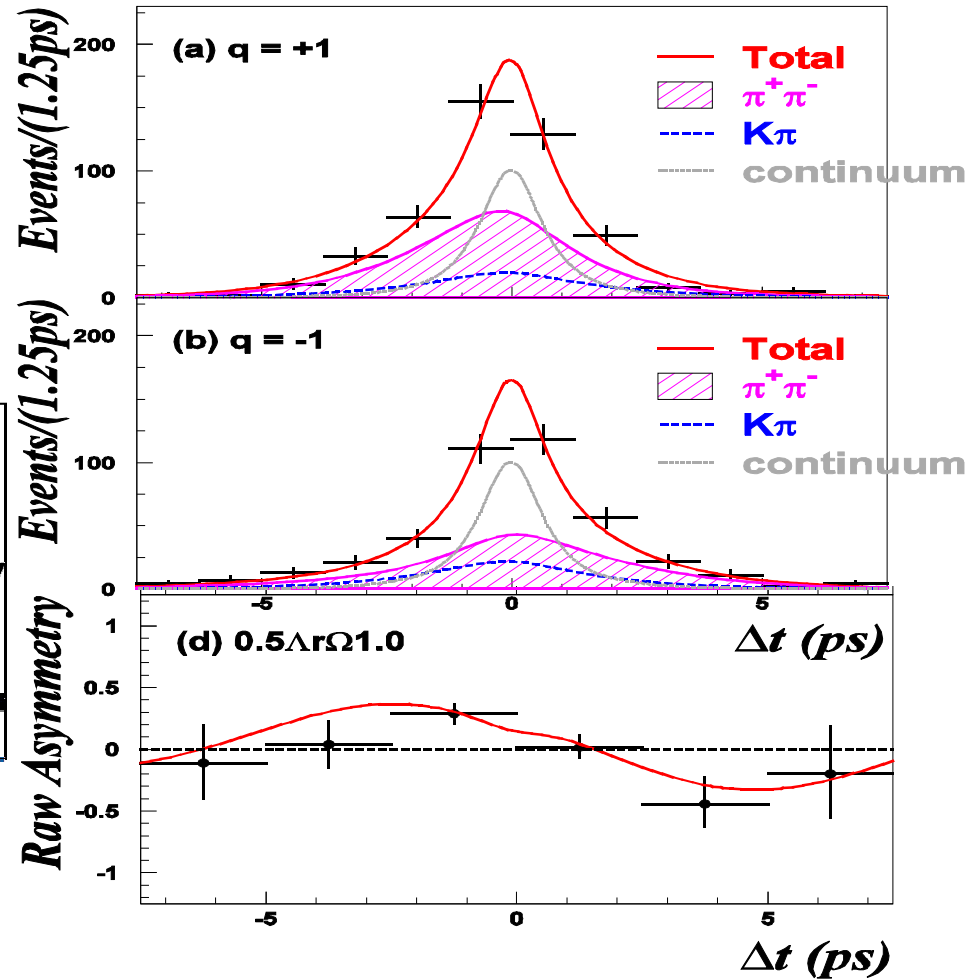



$B^0 \rightarrow \pi^+ \pi^-$ CPV measurement at BaBar



211 fb⁻¹

PRL 95, 151803 (2005)

$$C_{\pi\pi} = -0.09 \pm 0.15 \pm 0.04$$
$$S_{\pi\pi} = -0.30 \pm 0.17 \pm 0.03$$

No observation of CPV!

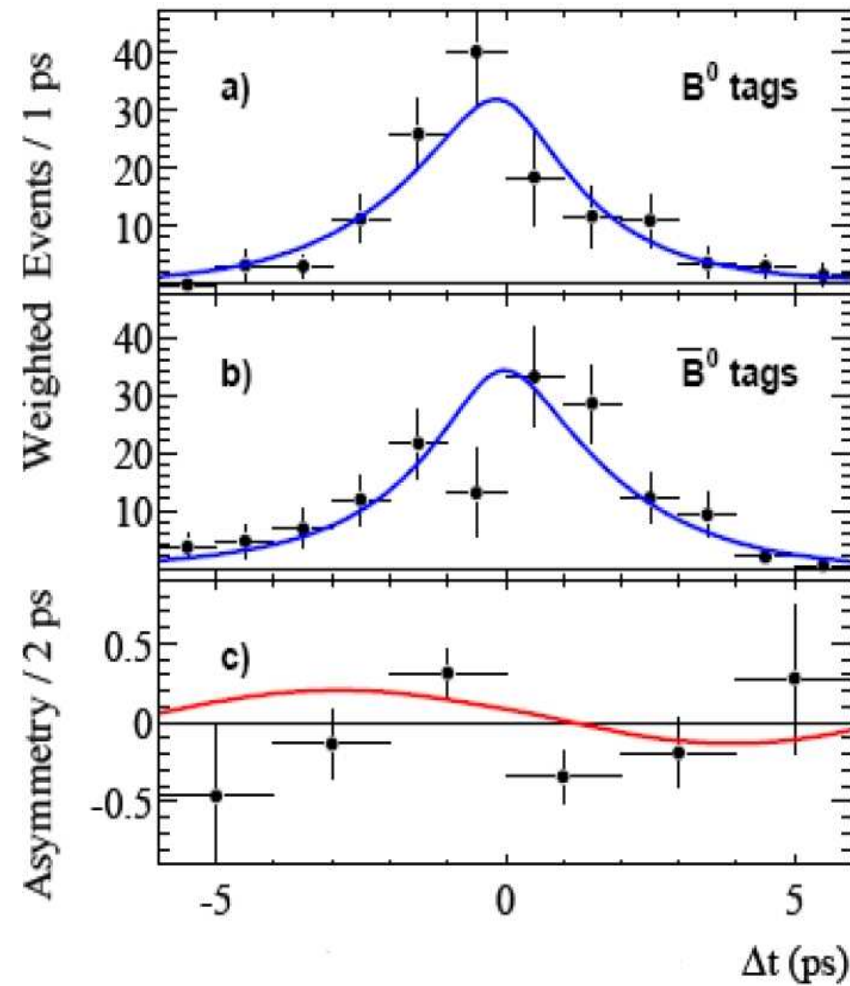
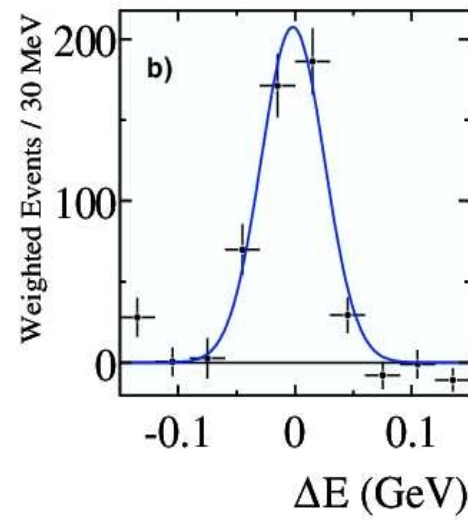
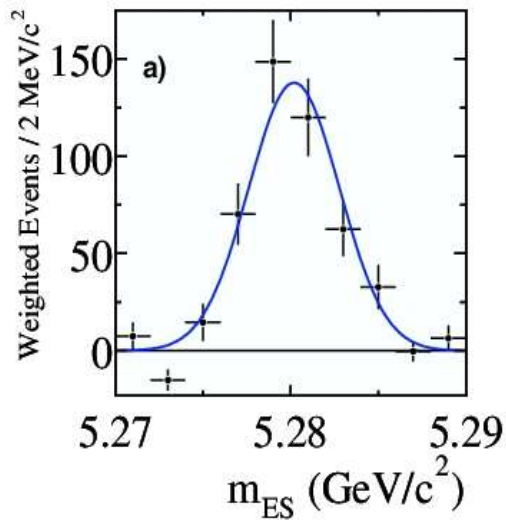



$B^0 \rightarrow \pi^+ \pi^-$ Experimental Summary

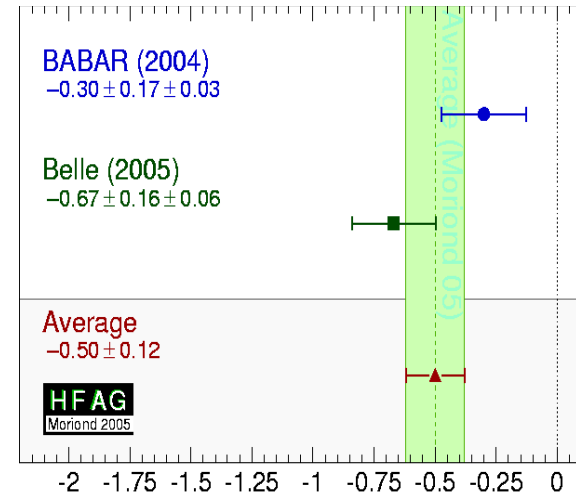
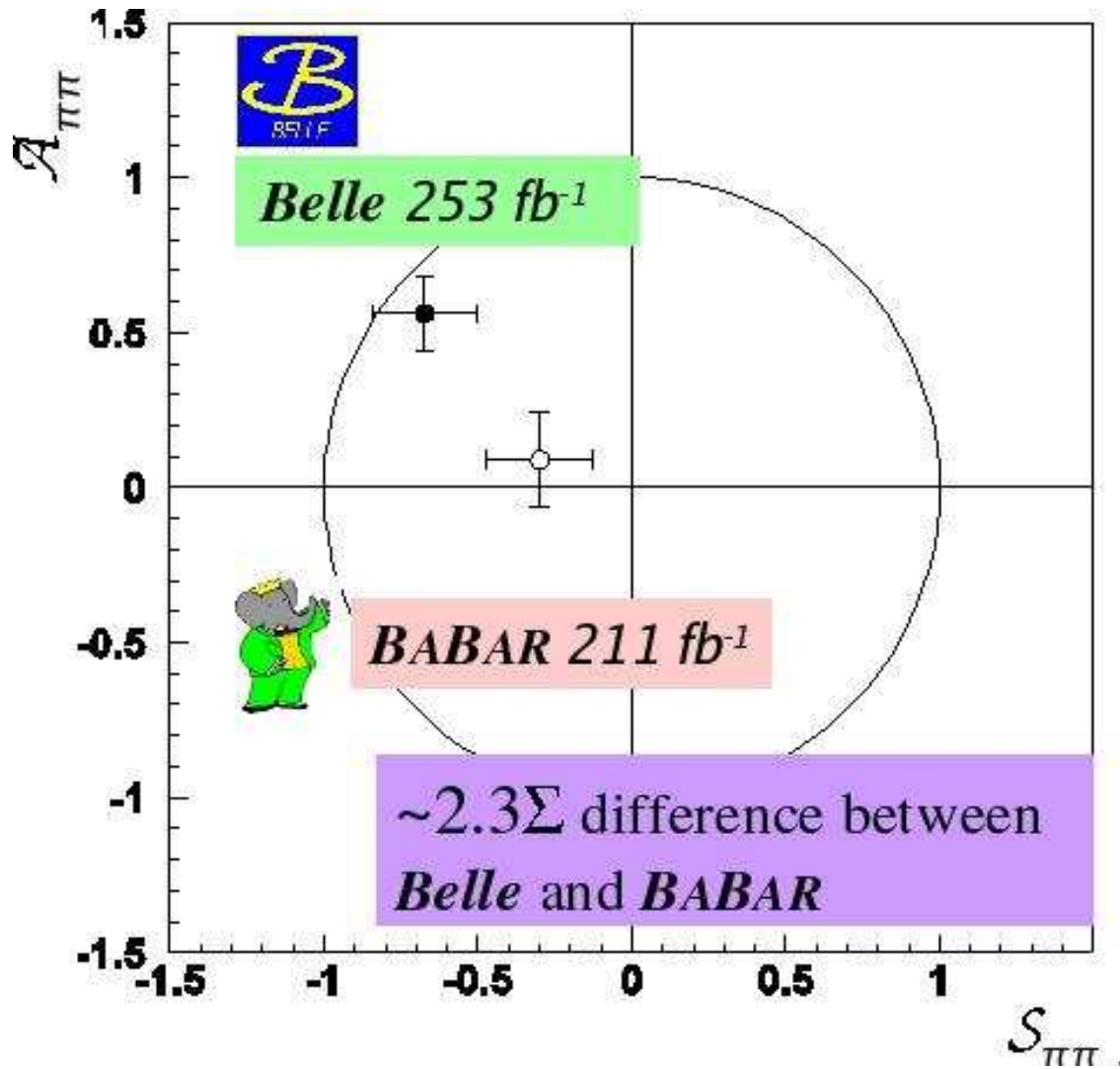

$S_{\pi\pi}$

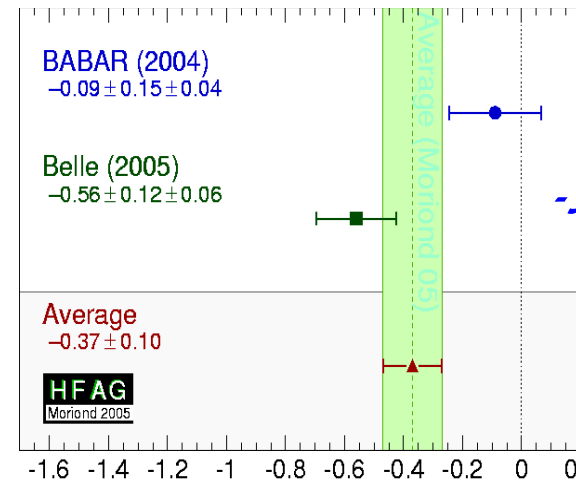

$-\mathcal{A}_{\pi\pi}(C_{\pi\pi})$



CPV measurement of $B^0 \rightarrow \rho^+ \rho^-$

Prospects for ϕ_2/α extraction:

- Good point
 - Small branching fraction of $B^0 \rightarrow \rho^0 \rho^0$ ($< 1/20$) compared with $B^0 \rightarrow \rho^+ \rho^-$ and $B^+ \rightarrow \rho^+ \rho^0$
 - Small penguin contribution
- Bad (difficult) points
 - two π^0 s are contained in the decay products
 - lower efficiency, larger BG
 - Consists of three polarization states
 - polarization measurement is essential



CPV measurement of $B^0 \rightarrow \rho^+ \rho^-$

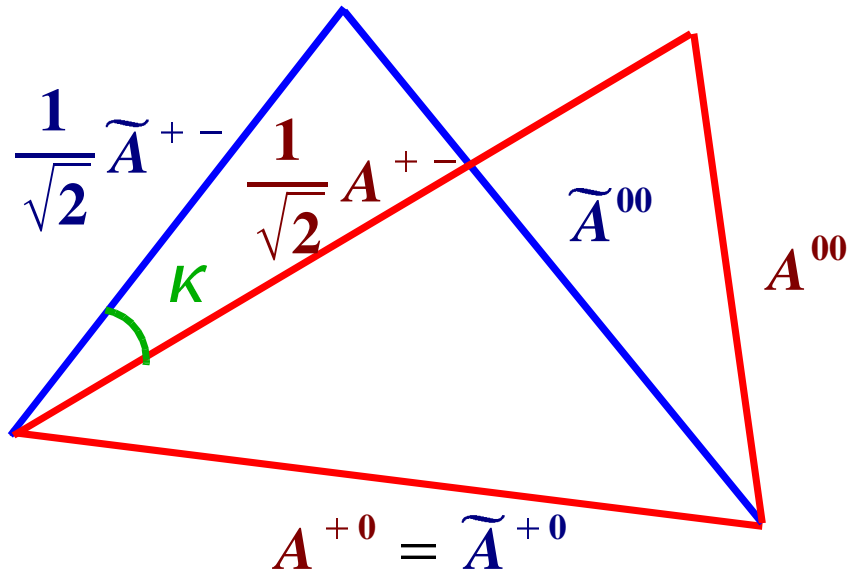

small branching ratio
of $B^0 \rightarrow \rho^0 \rho^0$

Inputs

$$\text{Br}(B^+ \rightarrow \rho^+ \rho^0) = (26 \pm 6) \times 10^{-6}$$

$$\text{Br}(B^0 \rightarrow \rho^+ \rho^-) = (26 \pm 4) \times 10^{-6}$$

$$\text{Br}(B^0 \rightarrow \rho^0 \rho^0) < 1.1 \times 10^{-6}$$

$$A(B^0 \rightarrow \rho^0 \rho^0) = \text{N.A.}$$

$$S(B^0 \rightarrow \rho^+ \rho^-) = -0.22 \pm 0.22$$

$$A(B^0 \rightarrow \rho^+ \rho^-) = -0.02 \pm 0.17$$



$B^0 \rightarrow \rho^0 \rho^0$ analysis at BaBar



PRL 94, 131801(2004)

211 fb⁻¹

$$\text{BR}(B^0 \rightarrow \rho^0 \rho^0) = (0.54^{+0.36}_{-0.32} \pm 0.19) \times 10^{-6}$$

$$\text{UL} < 1.1 \times 10^{-6} \text{ 90\% C.L.}$$

- Small branching ratio
 - small penguin contribution.
 - good sensitivity for ϕ_2/α extraction from $B^0 \rightarrow \rho^+ \rho^-$

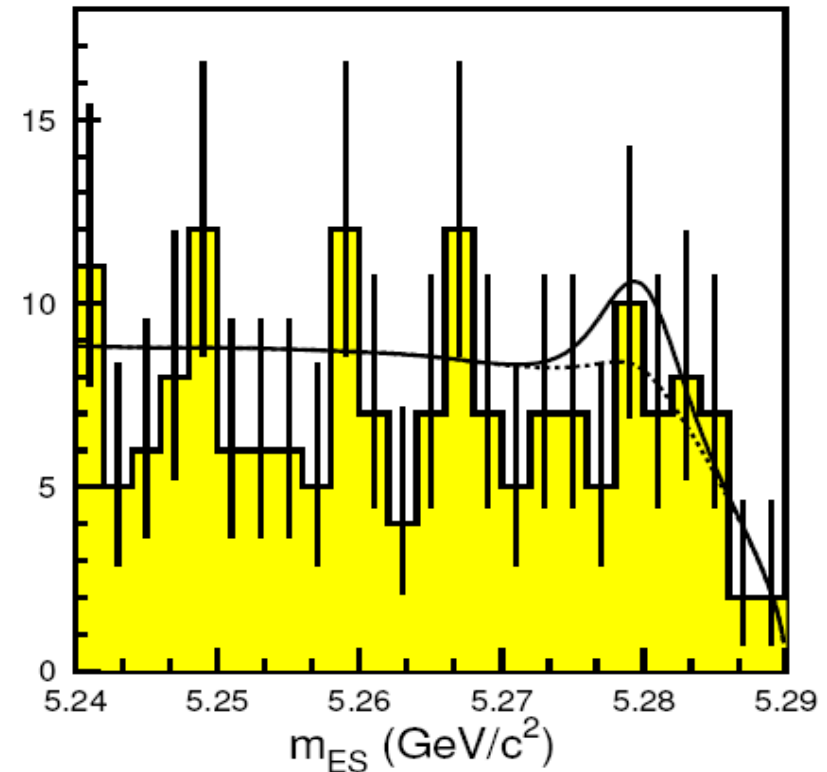



CPV measurement of $B^0 \rightarrow \rho^+ \rho^-$

Three polarization of $\rho^+ \rho^-$

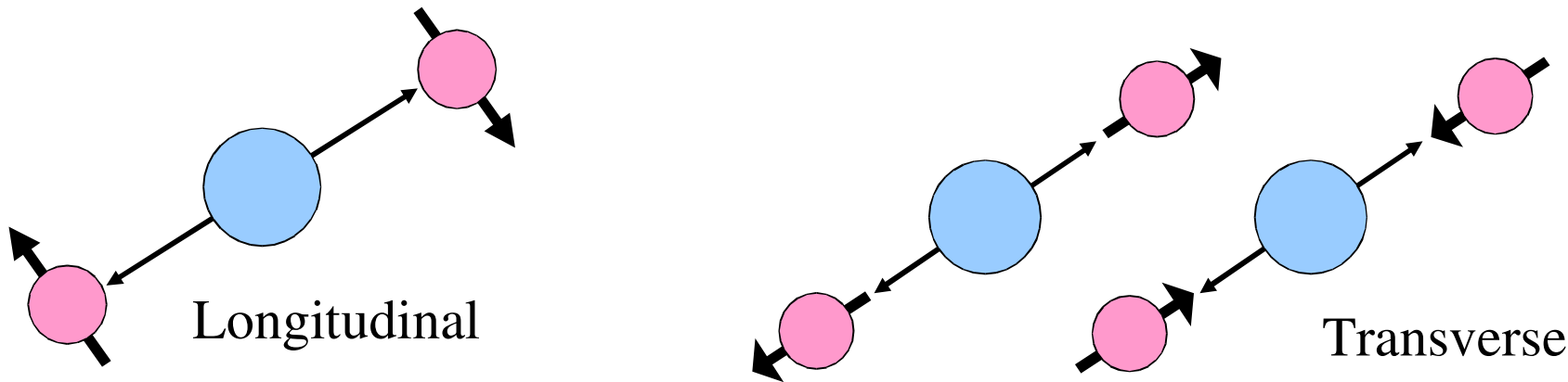

$$\frac{1}{\Gamma} \frac{d^2 \Gamma}{d \cos \theta_1 d \cos \theta_2} = \frac{9}{4} \left\{ \frac{1}{4} (1 - f_L) \sin^2 \theta_1 \sin^2 \theta_2 + f_L \cos^2 \theta_1 \cos^2 \theta_2 \right\}$$



$B^0 \rightarrow \rho^+ \rho^-$ CPV measurement at BaBar



PRL 95, 041805(2005)

211 fb⁻¹

$$f_L(\rho^+ \rho^-) = 0.978 \pm 0.014^{+0.021}_{-0.029}$$

$$C_L(\rho^+ \rho^-) = -0.03 \pm 0.18 \pm 0.09$$

$$S_L(\rho^+ \rho^-) = -0.33 \pm 0.24^{+0.08}_{-0.14}$$

$$\alpha = 100^\circ \pm 13^\circ$$
$$79^\circ < \alpha < 123^\circ \text{ (95\% C.L.)}$$

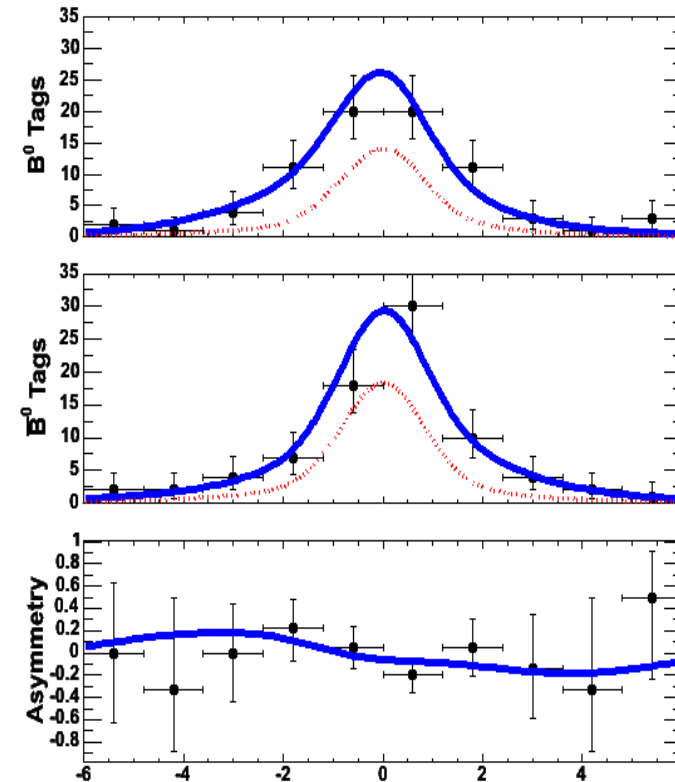
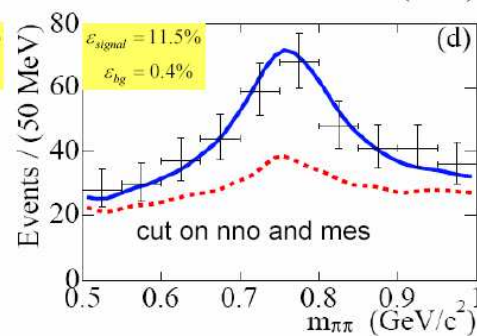
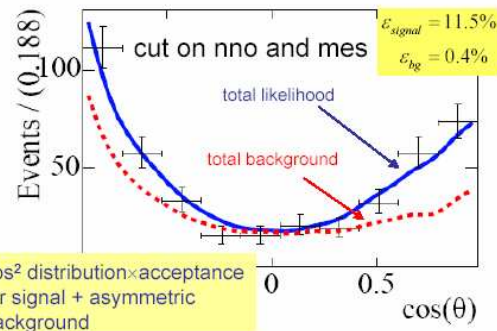
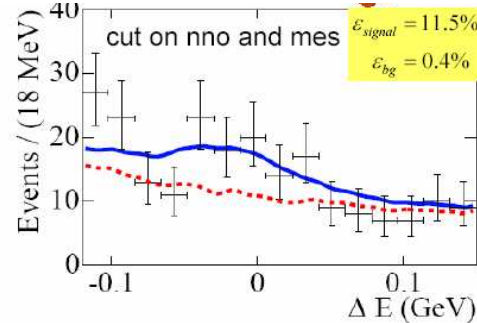
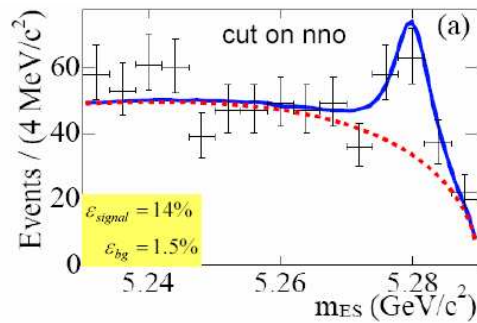



$B^0 \rightarrow \rho^+ \rho^-$ CPV measurement at Belle

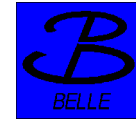

hep-ex/0601024

253 fb⁻¹

$$f_L = 0.941^{+0.034}_{-0.040} \pm 0.030$$

$$\mathcal{A}_{\rho\rho}^L = 0.00 \pm 0.30 \pm 0.09$$

$$\mathcal{S}_{\rho\rho}^L = 0.08 \pm 0.41 \pm 0.09$$

$$\phi_2 = 88^\circ \pm 17^\circ$$
$$59^\circ < \phi_2 < 115^\circ \text{ (95\% C.L.)}$$

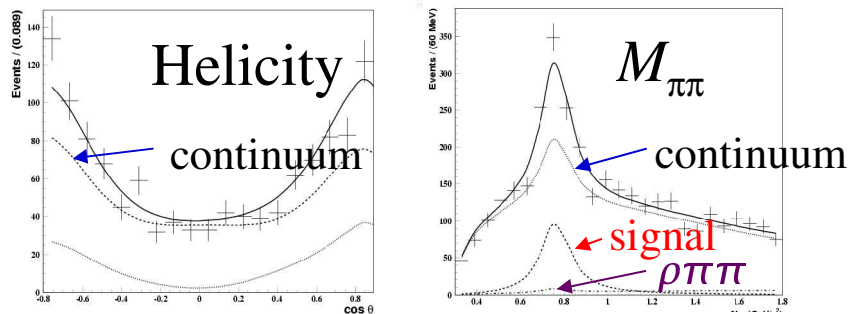
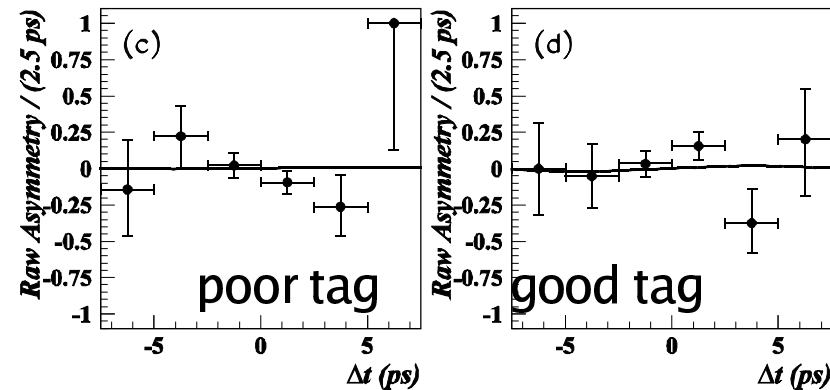
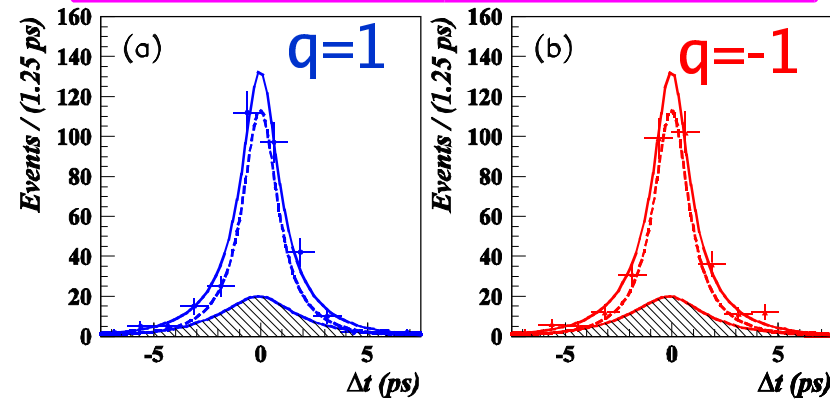
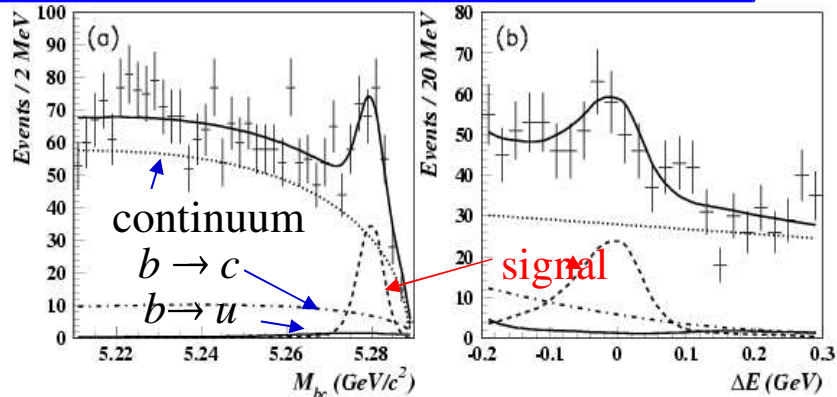

C.C.Wang

Flavor Physics & CP Violation

April 9-12, 2006 : Vancouver, B.C., Canada



Other $B \rightarrow \rho\rho$ measurements

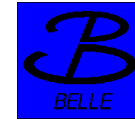

Belle/BaBar ($\times 10^{-6}$)

$$\text{Br}(B^0 \rightarrow \rho^+ \rho^-): 24.4 \pm 2.2^{+3.8}_{-4.1} / 30 \pm 4 \pm 5$$

$$\text{Br}(B^+ \rightarrow \rho^+ \rho^0): 31.7 \pm 7.1^{+3.8}_{-6.7} / 17.2 \pm 2.5 \pm 2.8$$

$$f_L: 0.95 \pm 0.11 \pm 0.02 / 0.96 \pm 0.04 \pm 0.05$$

06 Moriond QCD

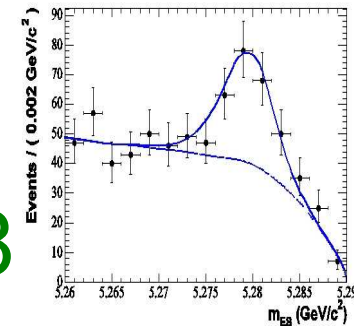



ϕ_2/α summary of $B^0 \rightarrow \rho^+ \rho^-$

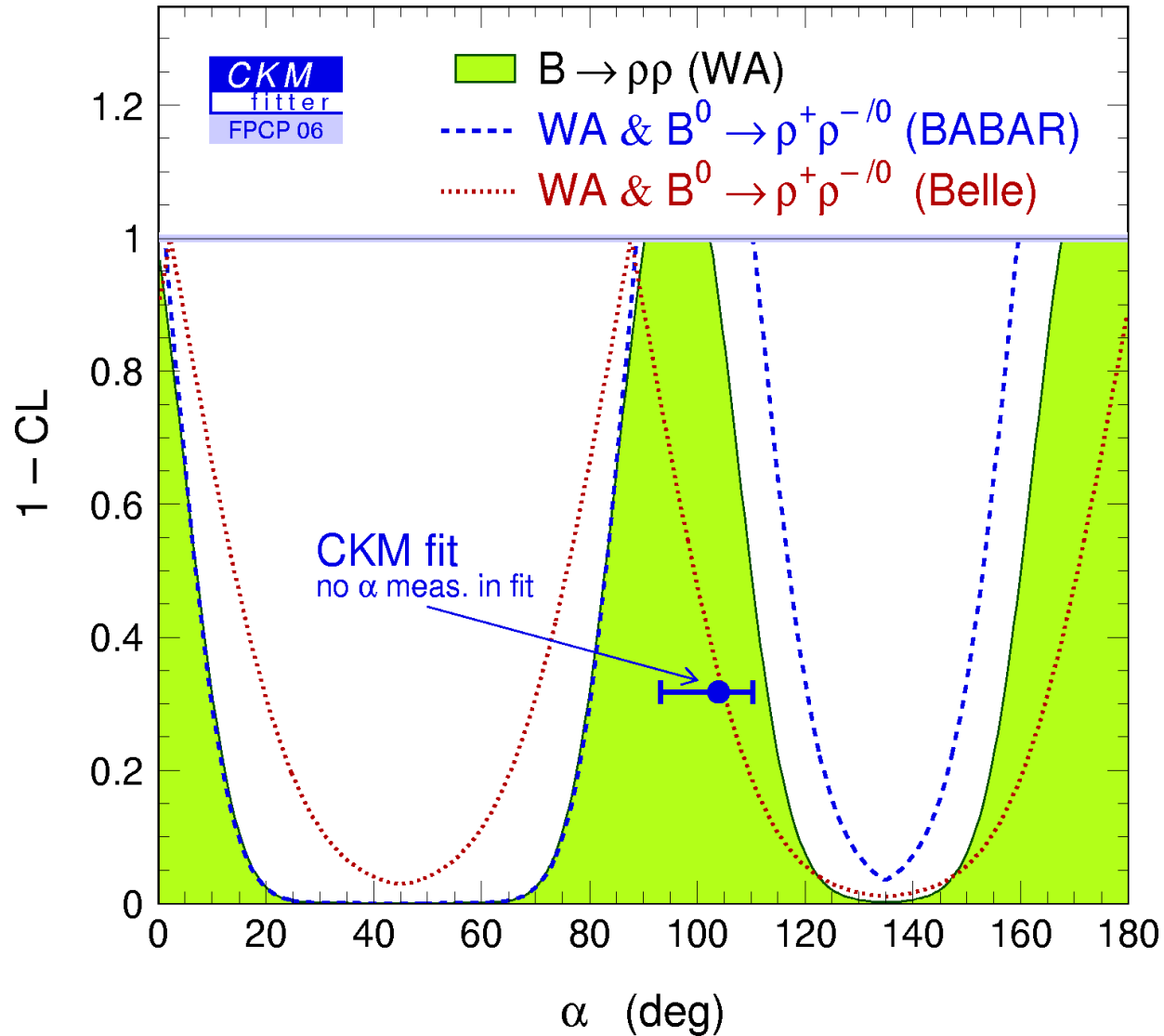



CPV measurement of $B^0 \rightarrow \rho^\pm \pi^\mp (\pi^+ \pi^- \pi^0)$

Prospects for ϕ_2/α extraction:

- Good point
 - two scenarios by assuming isospin symmetry:
 - quasi-two-body approach.
 - direct measurement of ϕ_2/α from Dalitz analysis.
- Bad (difficult) points of Dalitz analysis
 - complicated $\pi^+ \pi^- \pi^0$ resonant modes
 - higher resonance.
 - ρ - ω mixing.
 - other resonance.
 - complicated backgrounds on Dalitz plot.



$B^0 \rightarrow \rho^\pm \pi^\mp$ CPV measurement at Belle

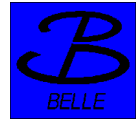

PRL 94, 121801(2005)

$$\begin{aligned}
 A_{CP}^{\rho\pi} &= -0.16_{-0.10}^{+0.09} \pm 0.02 \\
 C_{\rho\pi} &= 0.25_{-0.17-0.06}^{+0.16+0.02} \\
 S_{\rho\pi} &= -0.28_{-0.22-0.08}^{+0.23+0.10} \\
 \Delta C_{\rho\pi} &= 0.38_{-0.18-0.04}^{+0.17+0.02} \\
 \Delta S_{\rho\pi} &= -0.30_{-0.23}^{+0.24} \pm 0.09
 \end{aligned}$$

Direct CP Violation:

$$\begin{aligned}
 A_{+-} &= \frac{|\overline{A}^{+-}|^2 - |A^{-+}|^2}{|\overline{A}^{+-}|^2 + |A^{-+}|^2} = \frac{A_{\rho\pi} - C_{\rho\pi} - A_{\rho\pi} \Delta C_{\rho\pi}}{1 - \Delta C_{\rho\pi} - A_{\rho\pi} C_{\rho\pi}} = -0.02_{-0.15-0.02}^{+0.16+0.05} \\
 A_{-+} &= \frac{|\overline{A}^{-+}|^2 - |A^{+-}|^2}{|\overline{A}^{-+}|^2 + |A^{+-}|^2} = -\frac{A_{\rho\pi} + C_{\rho\pi} + A_{\rho\pi} \Delta C_{\rho\pi}}{1 + \Delta C_{\rho\pi} + A_{\rho\pi} C_{\rho\pi}} = -0.53_{-0.28-0.04}^{+0.29+0.09}
 \end{aligned}$$

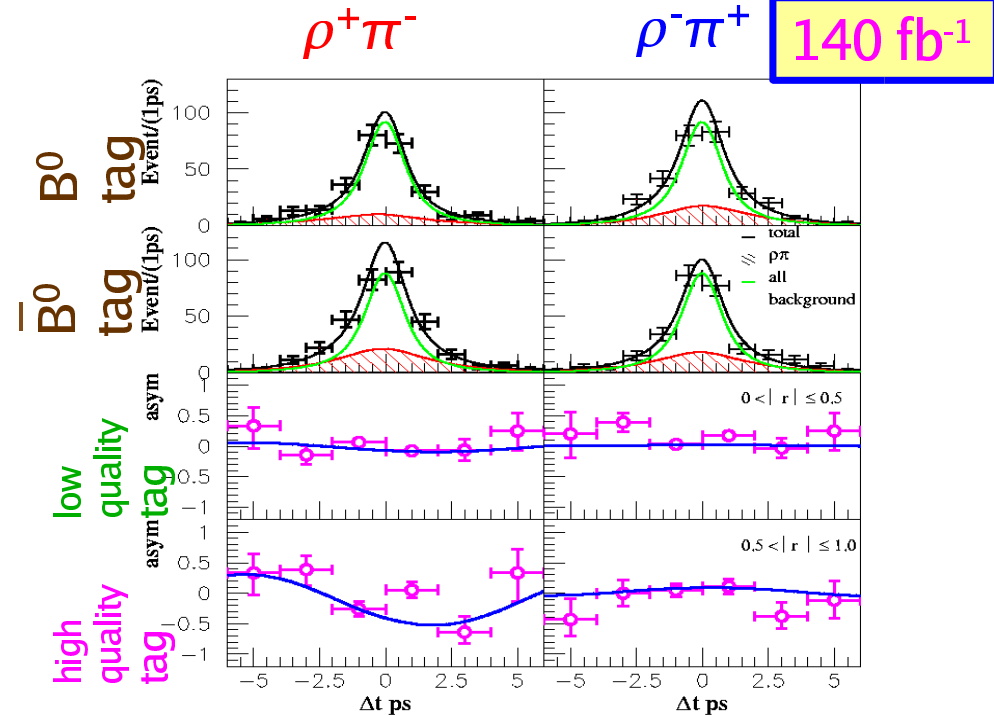



$B^0 \rightarrow \rho^0 \pi^0$ measurement from Belle

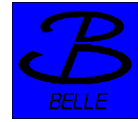

hep-ex/0508007

357 fb⁻¹

$$\text{Br}(B^0 \rightarrow \rho^0 \pi^0) : (3.12^{+0.88}_{-0.82} \pm 0.33^{+0.50}_{-0.68}) 10^{-6}$$

$$A_{\text{CP}} = -0.53^{+0.67+0.10}_{-0.84-0.15}$$

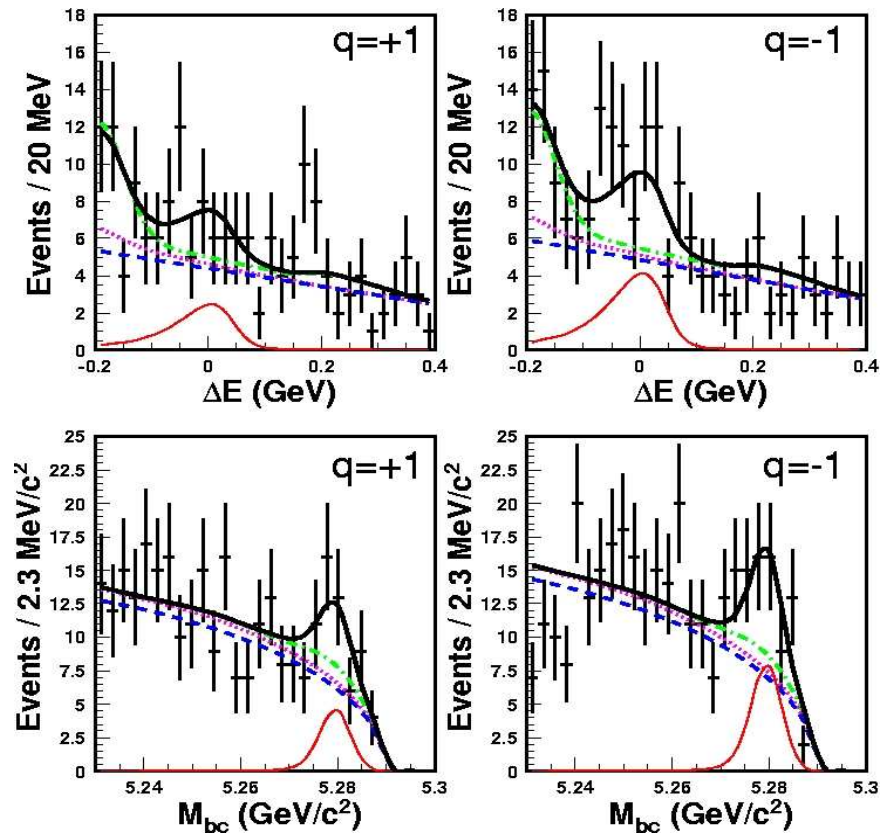



$B^0 \rightarrow \rho^\pm \pi^\mp (\pi^+ \pi^- \pi^0)$ CPV measurement at BaBar



hep-ex/0408099

192 fb⁻¹

Time dependent Dalitz analysis by assuming isospin symmetry:

$$A(B^0 \rightarrow \pi^+ \pi^- \pi^0) = f_+ A(\rho^+ \pi^-) + f_- A(\rho^- \pi^+) + f_0 A(\rho^0 \pi^0)$$

$$\bar{A}(\bar{B}^0 \rightarrow \pi^+ \pi^- \pi^0) = f_+ \bar{A}(\rho^+ \pi^-) + f_- \bar{A}(\rho^- \pi^+) + f_0 \bar{A}(\rho^0 \pi^0)$$

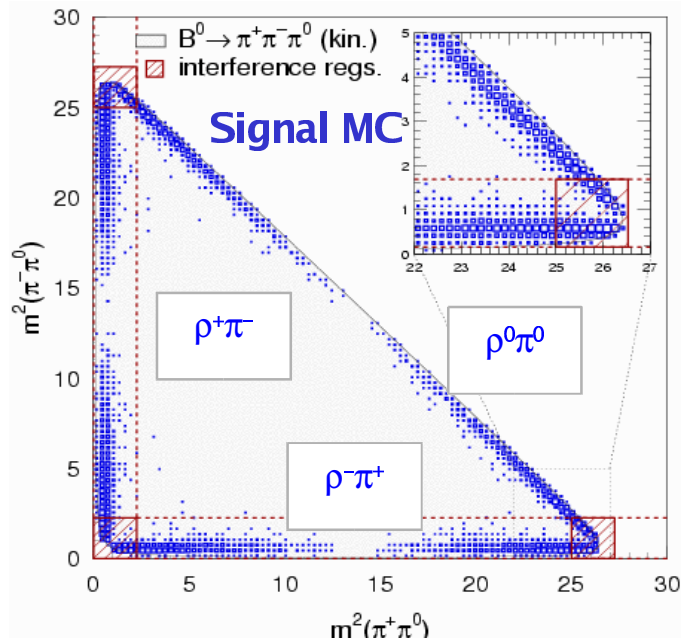

$$\Delta C_{\rho\pi}^{\rho\pi} = -0.088 \pm 0.049 \pm 0.013$$

$$C_{\rho\pi} = 0.34 \pm 0.11 \pm 0.05$$

$$S_{\rho\pi} = -0.10 \pm 0.14 \pm 0.04$$

$$\Delta C_{\rho\pi} = 0.15 \pm 0.11 \pm 0.03$$

$$\Delta S_{\rho\pi} = 0.22 \pm 0.15 \pm 0.03$$



$B^0 \rightarrow \rho^\pm \pi^\mp (\pi^+ \pi^- \pi^0)$ CPV measurement at BaBar

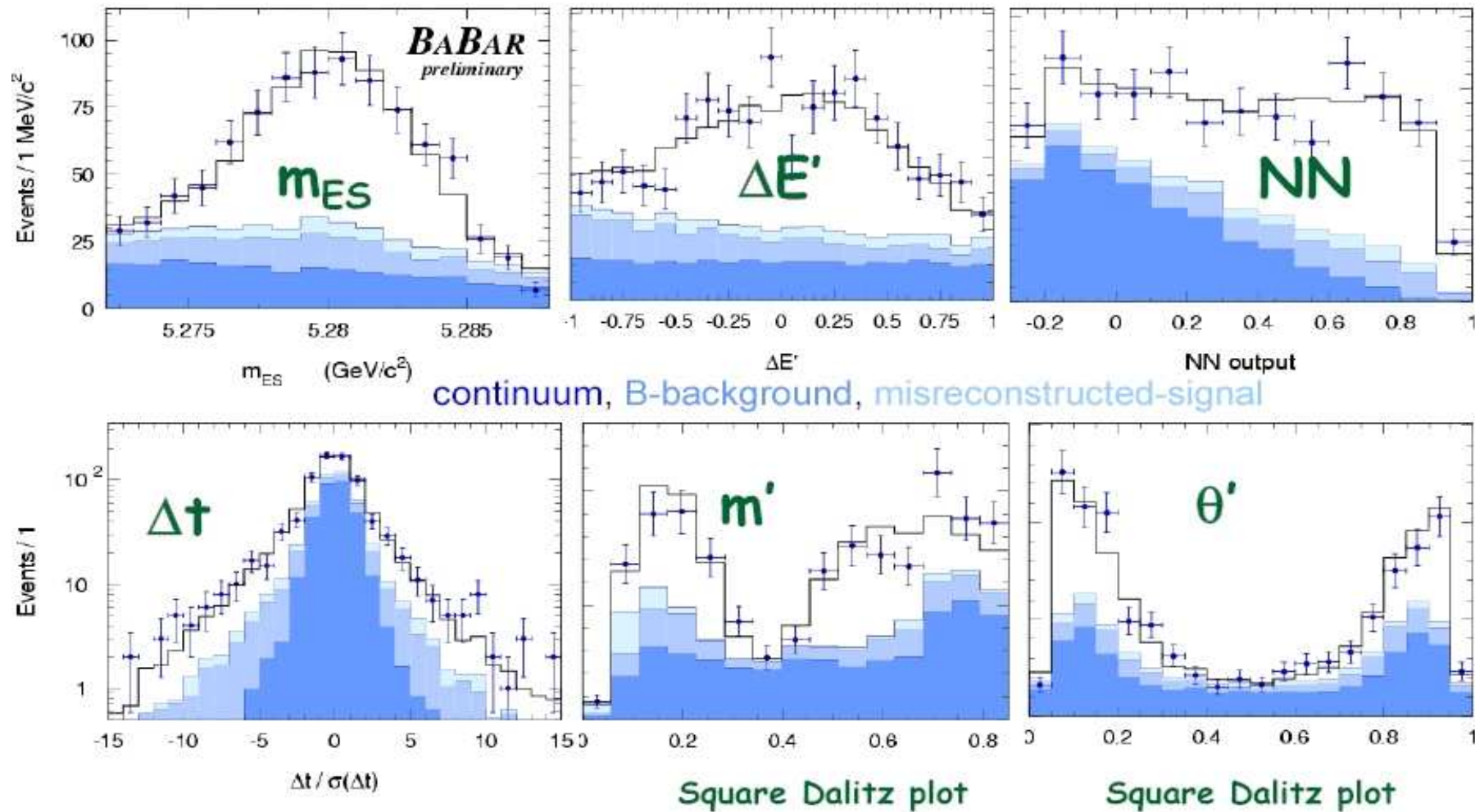



$B^0 \rightarrow \rho^\pm \pi^\mp (\pi^+ \pi^- \pi^0)$ ϕ_2 from BaBar



192 fb⁻¹

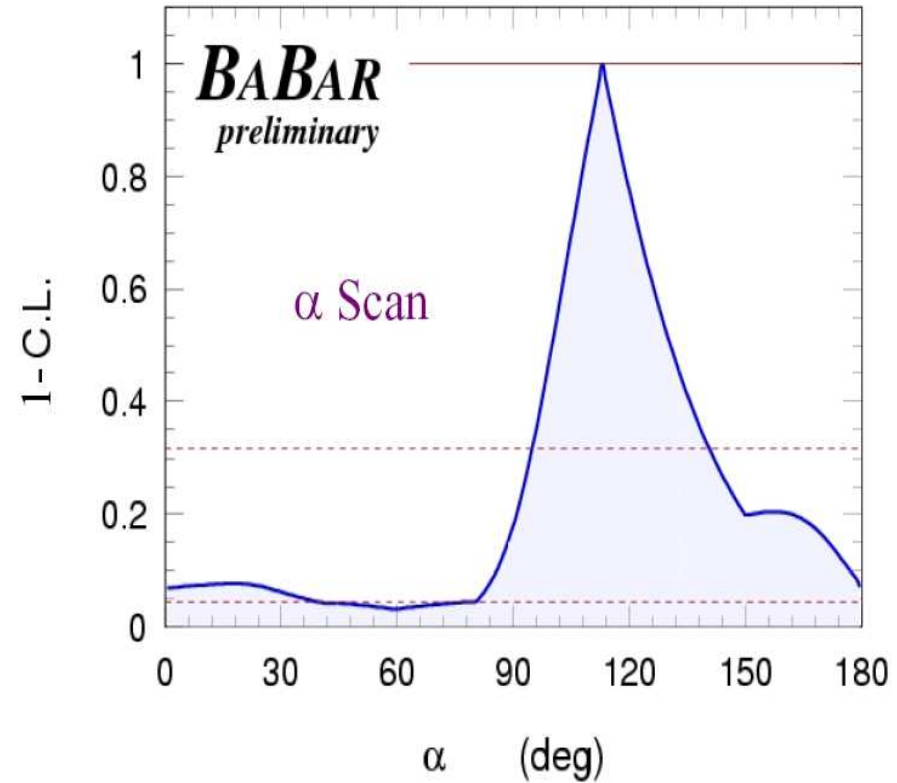
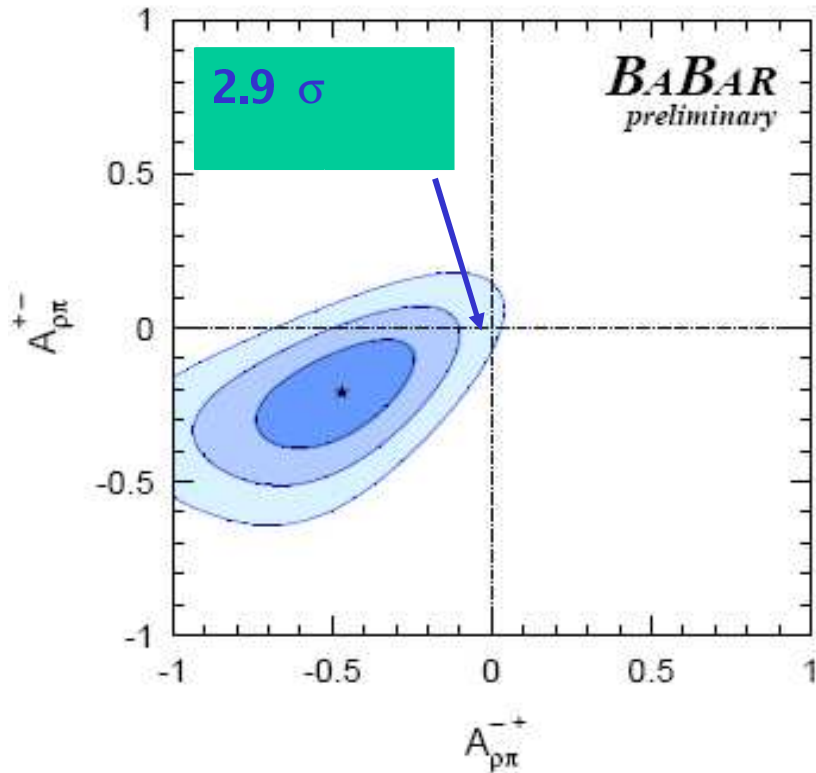

$$A_{+-} = A_{-+}^{\rho\pi} = -0.47_{-0.15}^{+0.14} \pm 0.06$$

$$A_{-+} = A_{+-}^{\rho\pi} = -0.21 \pm 0.11 \pm 0.04$$

$$\alpha = (113_{-17}^{+27} \pm 6)^\circ$$



Combined ϕ_2/α constraint

$$\phi_2 = 99^{+12}_{-9}^\circ$$

- Note:

- EWP is not included
 - about $1\sim 2^\circ$ effect.
- Isospin triangle for $\rho\rho$ does not close.
- $\pi\pi$ results still have some discrepancies.

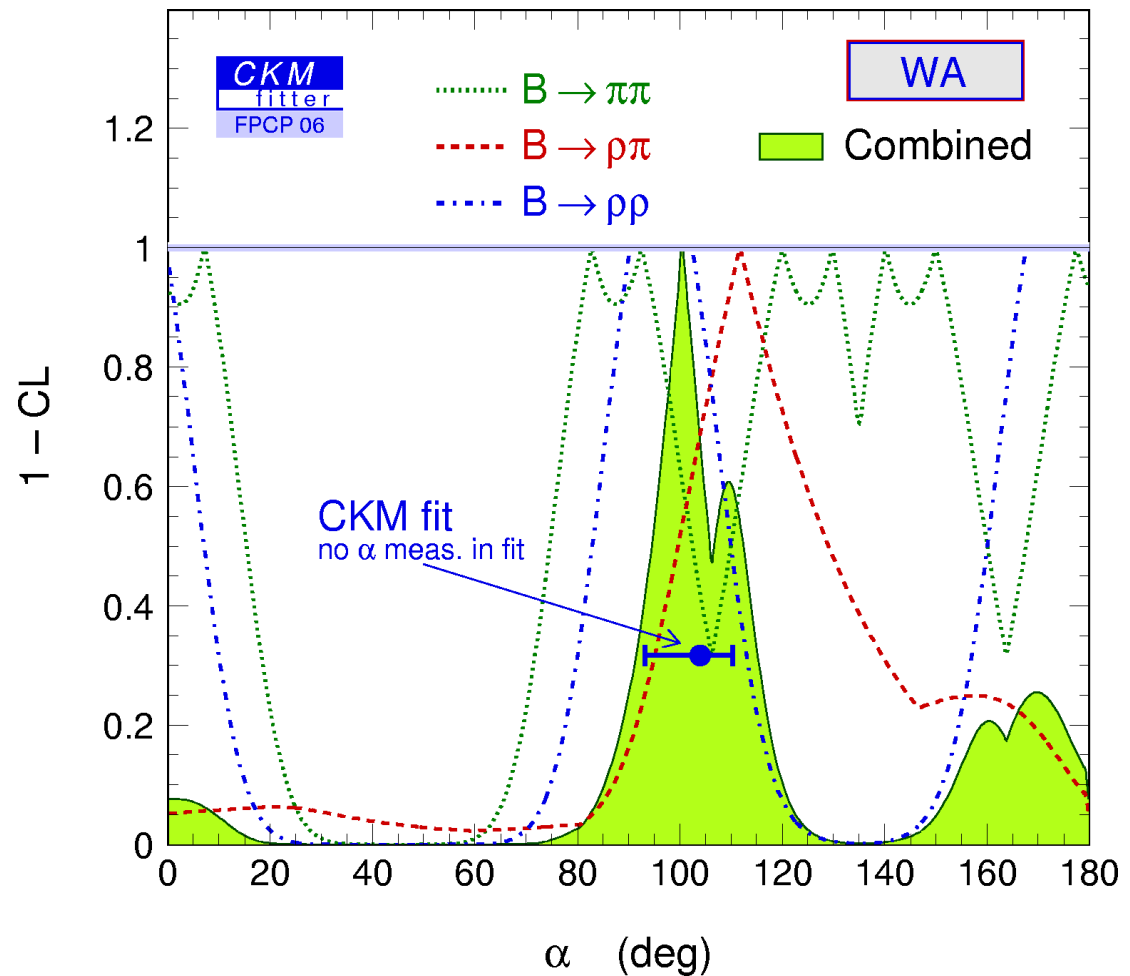



Combined ϕ_2/α constraint

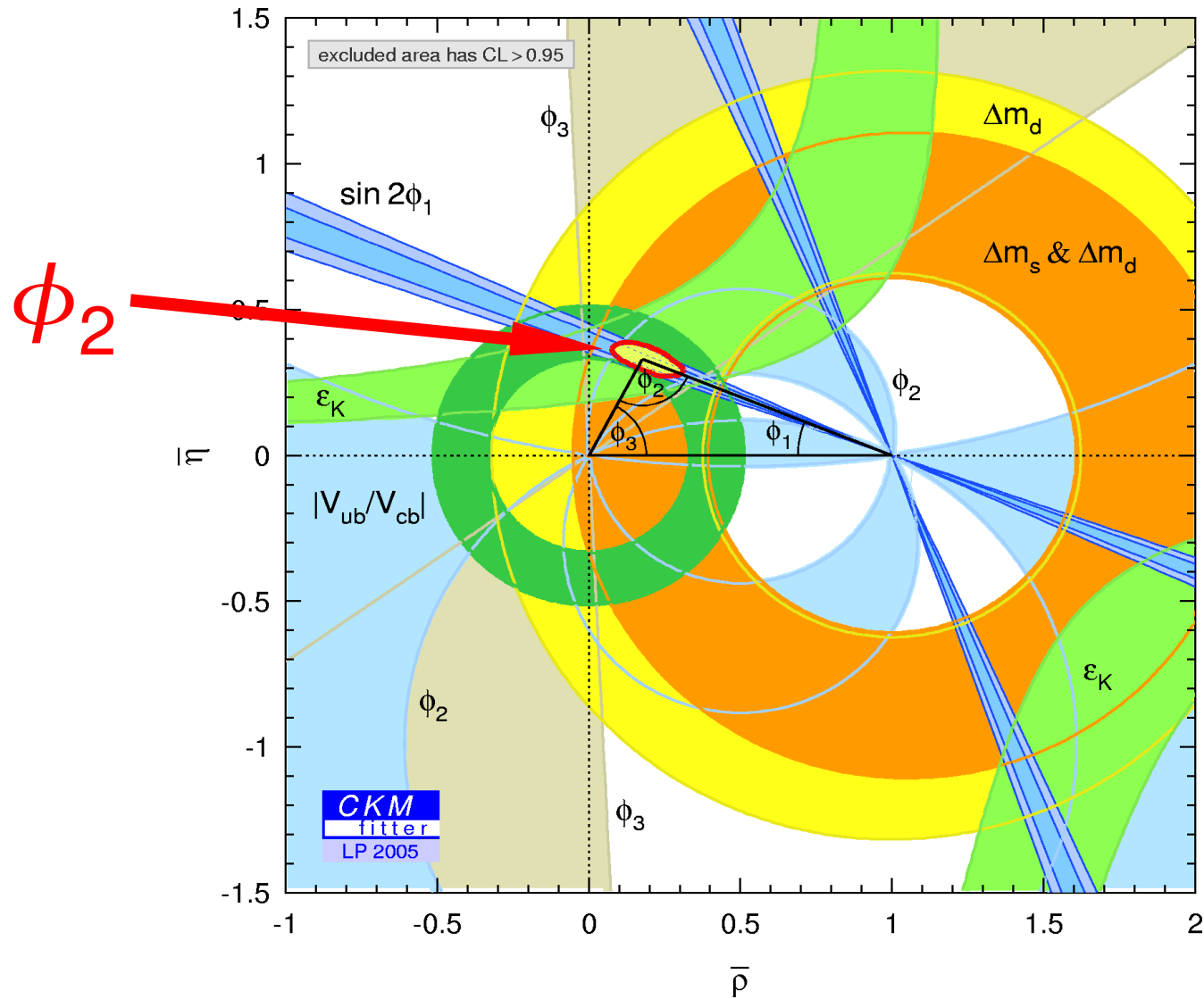



Prospects for ϕ_2/α measurement

- Coming $B \rightarrow \pi^+ \pi^- \pi^0$ result from B factory.
 - Improve the direct measurement of ϕ_2/α .
- $B \rightarrow \rho\rho$ and $B \rightarrow \pi\pi$ with more data.
- ϕ_2 constraint from $B^0 \rightarrow a_1 \pi$ is possible.
 -  $\text{Br}(B^0 \rightarrow a_1 \pi) = (40.2 \pm 3.9 \pm 3.9) \times 10^{-6}$ (Moriond QCD 06).
- Some other modes.
 - $K^{*0} \rho^+$, $\omega \rho$...etc.....



Backup Slides



Introduction of Time-dependent Analysis

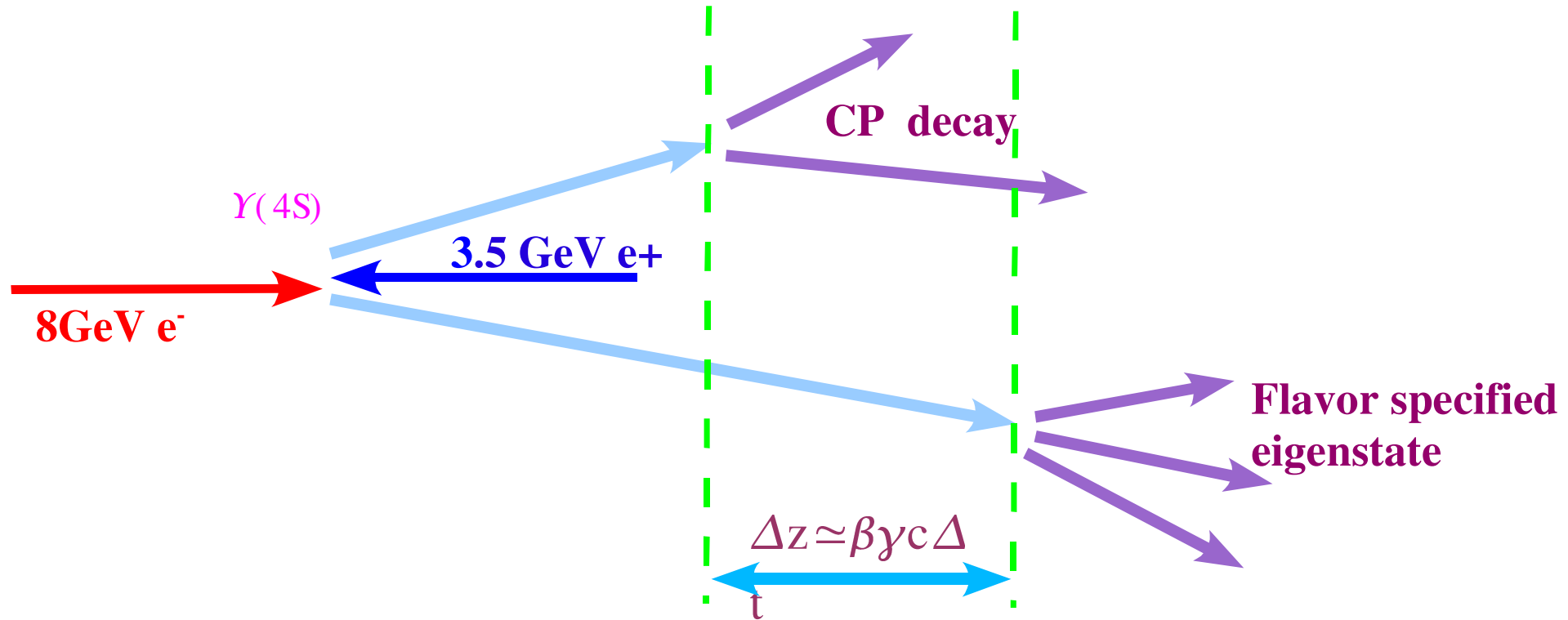



ρ - ω mixing

- Implement the ρ - ω mixing form factor based on ALEPH and CMD-2 result.

$$F(s) = \frac{BW_{\rho(770)}^{GS}(s) \frac{1 + \delta BW_{\omega(783)}^{GS}(s)}{1 + \delta} + \beta BW_{\rho(1450)}^{GS}(s) + \gamma BW_{\rho(1700)}^{GS}(s)}{1 + \beta + \gamma}$$

$$BW_M^{GS}(s) = \frac{M^2 (1 + d \cdot \Gamma / M)}{M - s + f(s) - i \sqrt{s} \Gamma(s)}$$

- Implement the kinematic function.



KEKB and Belle

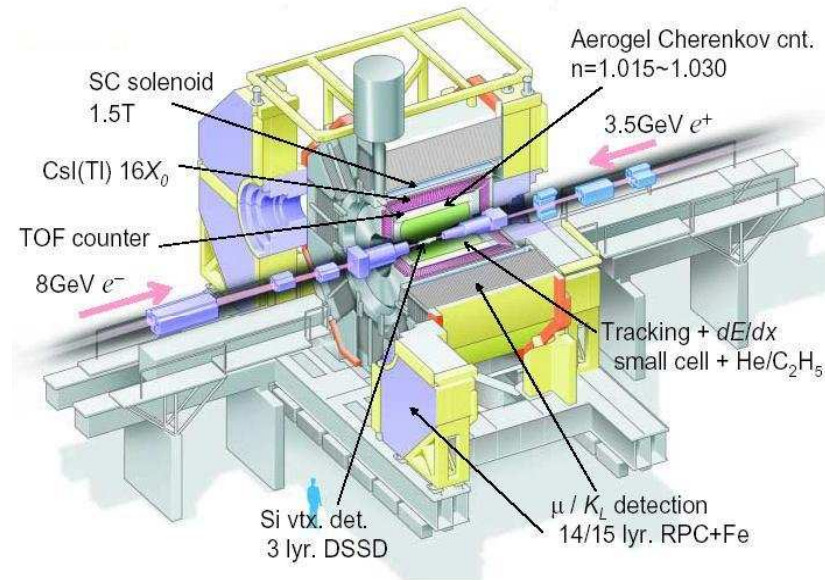
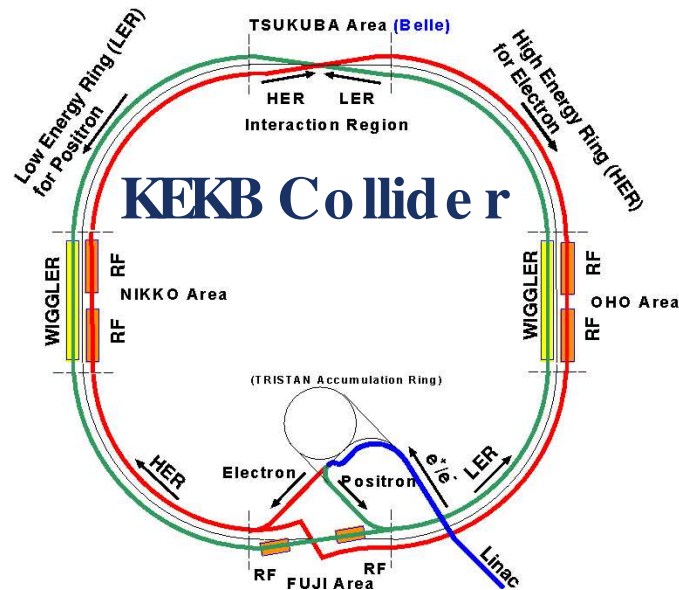

3.5 GeV e^+ & 8 GeV e^- beams
 3 km circumference, 11 mrad crossing angle
 $L = 1.63 \times 10^{34} \text{ cm}^{-2}\text{s}^{-1}$ (world record)
 $L dt = 550 \text{ fb}^{-1} @ Y(4S) + \text{off} (\sim 10\%)$

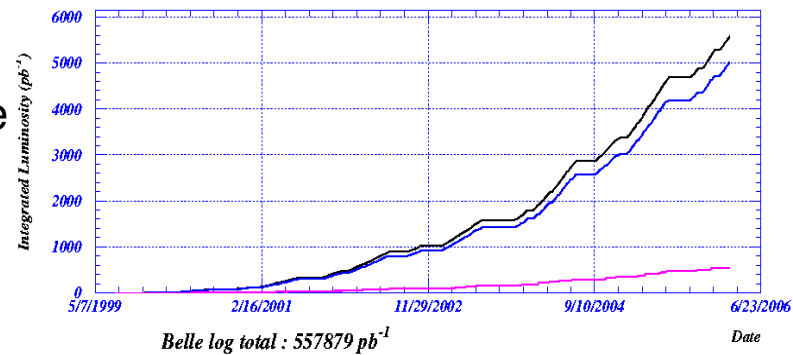



PEPII and BaBar

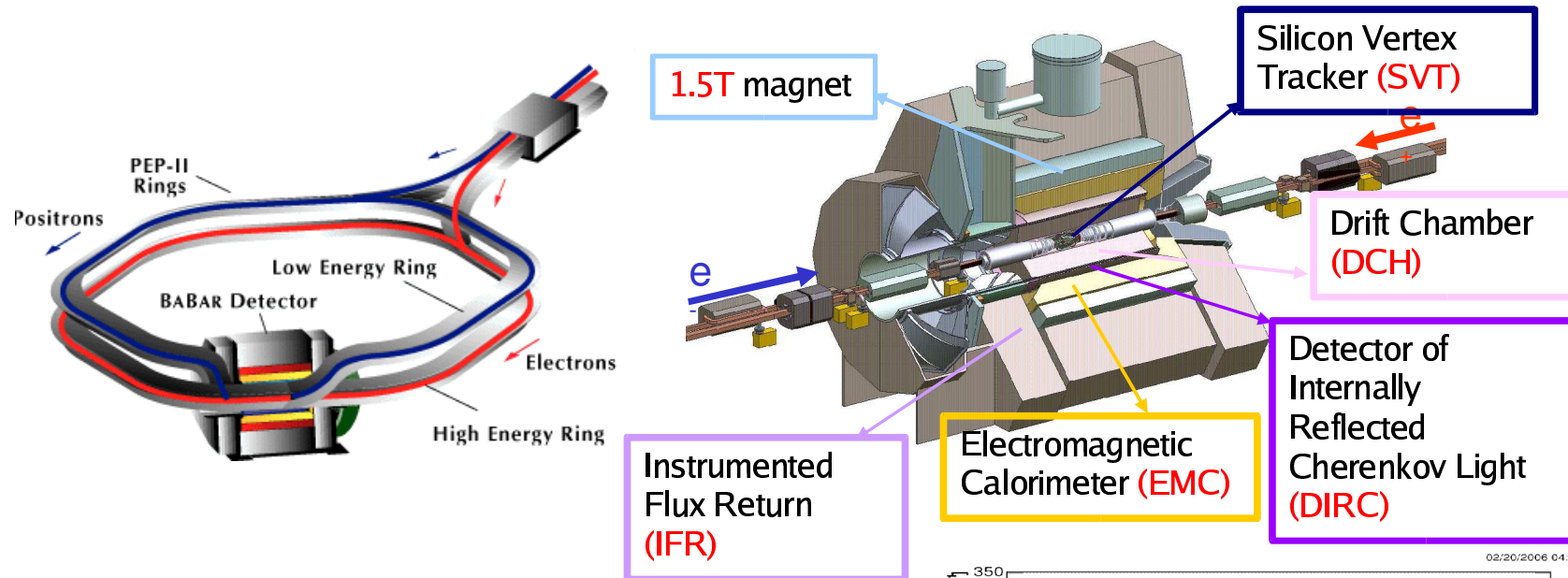

3.1 GeV e^+ & 9 GeV e^- beams

$L = 1.00 \times 10^{34} \text{ cm}^{-2}\text{s}^{-1}$ (Oct 9, 2005)

$L dt = 335 \text{ fb}^{-1}$ @ $Y(4S)+\text{off}$ (~10%)





$B^0 \rightarrow \pi^0 \pi^0$ Result

Belle:

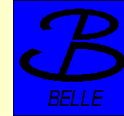

PRL 94, 181803 (2005)

$$\text{BR}(B^0 \rightarrow \pi^0 \pi^0) = (2.3^{+0.4+0.2}_{-0.5-0.3}) \times 10^{-6}$$

$$A_{\text{cp}} = 0.44^{+0.53}_{-0.52} \pm 0.17$$

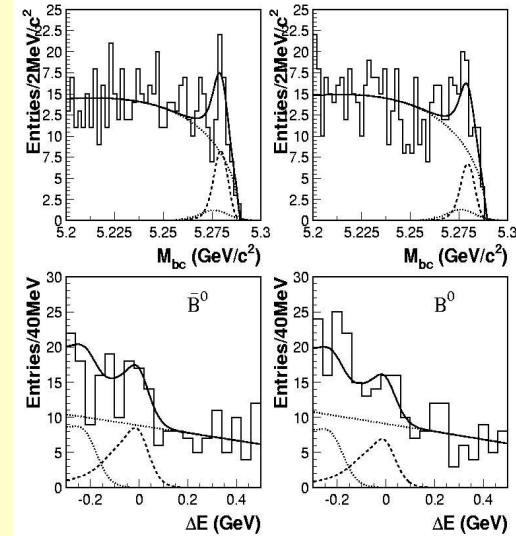

BaBar:



PRL 94, 181802 (2005)

$$\text{BR}(B^0 \rightarrow \pi^0 \pi^0) = (1.17 \pm 0.32 \pm 0.10) \times 10^{-6}$$

$$A_{\text{cp}} = 0.12 \pm 0.56 \pm 0.06$$



ϕ_2/α constraint from $B^0 \rightarrow \pi^+ \pi^-$

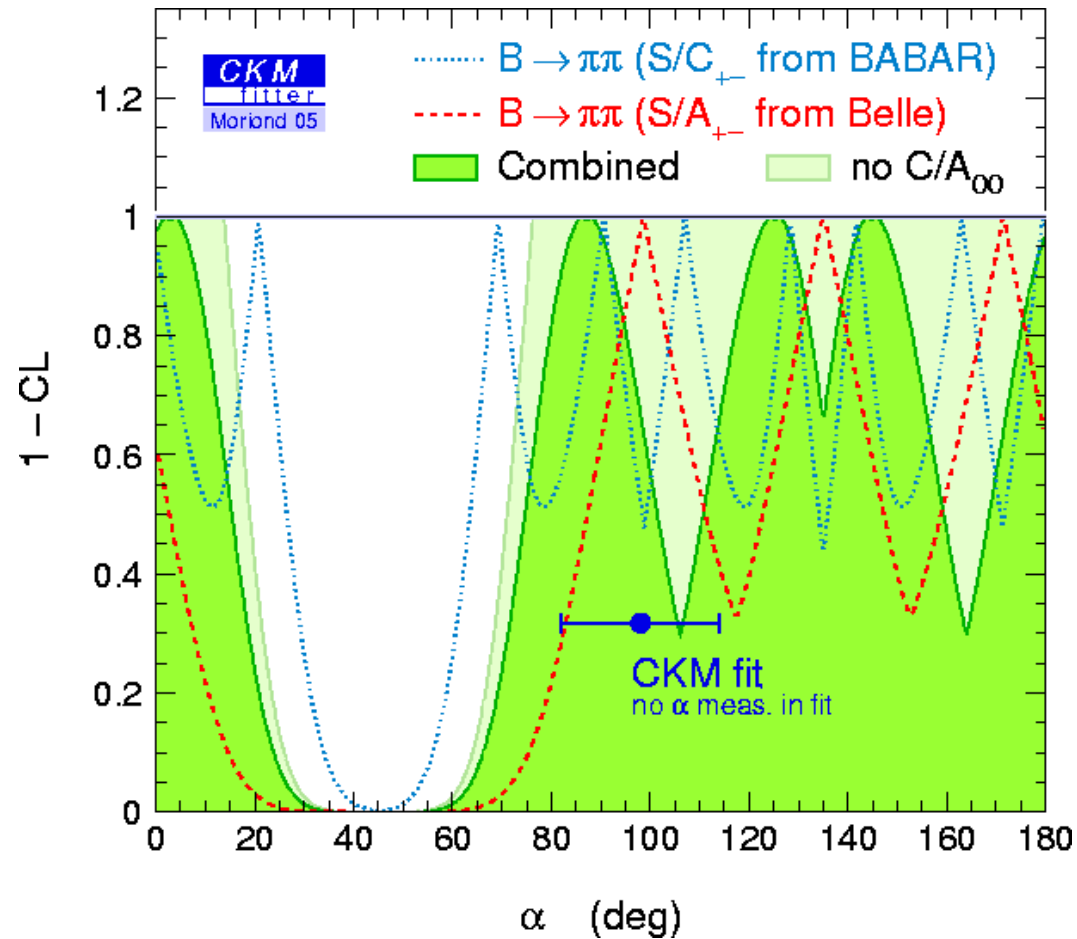



$B^0 \rightarrow \rho^\pm \pi^\mp (\pi^+ \pi^- \pi^0)$ ϕ_2 from BaBar

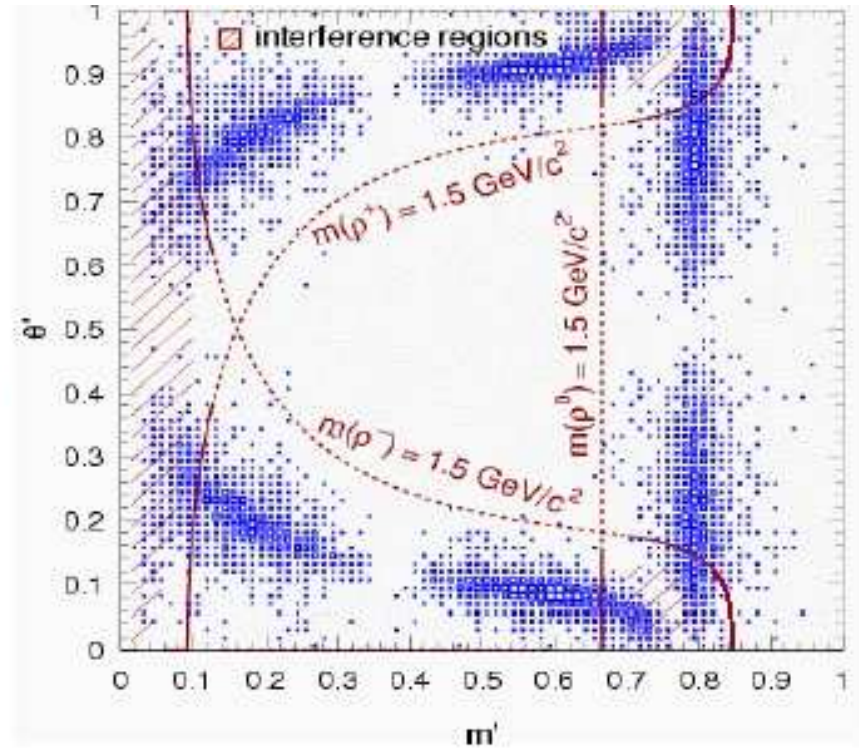
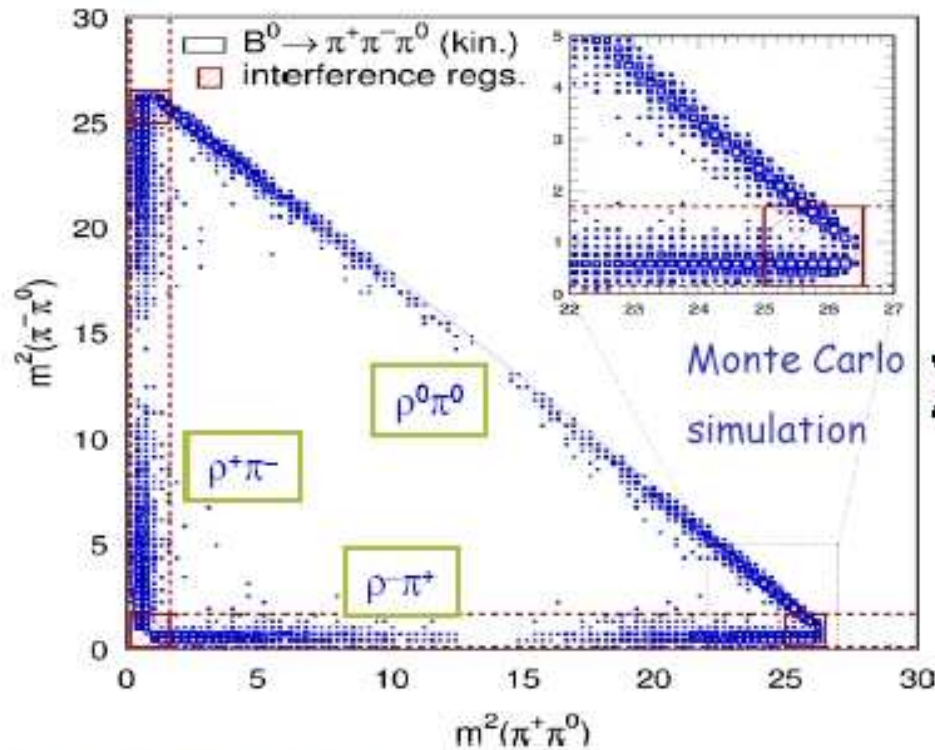

Square Dalitz plot: more uniform repartition of events. Better parametrization.

$$m' \equiv \frac{1}{\pi} \arccos \left(2 \frac{m_{+-} - m_{+-}[\min]}{m_{+-}[\max] - m_{+-}[\min]} - 1 \right),$$

$$\theta' \equiv \frac{1}{\pi} \theta_{+-}$$

$$m_{+-}[\max] = m_{B^0} - m_{\pi^0}$$

$$m_{+-}[\min] = 2m_{\pi^+}$$

θ_{+-} is the angle between the pos. track and neg. B^0 momentum in the $\{+-\}$ rest frame



$B^0 \rightarrow a_1 \pi$

$$\text{Br}(B^0 \rightarrow a_1 \pi) = (40.2 \pm 3.9 \pm 3.9) \times 10^{-6}$$

$$m_{a_1} = 1.22 \pm 0.02 \text{ GeV}/c^2$$

$$\Gamma_{a_1} = 0.423 \pm 0.050 \text{ GeV}/c^2$$

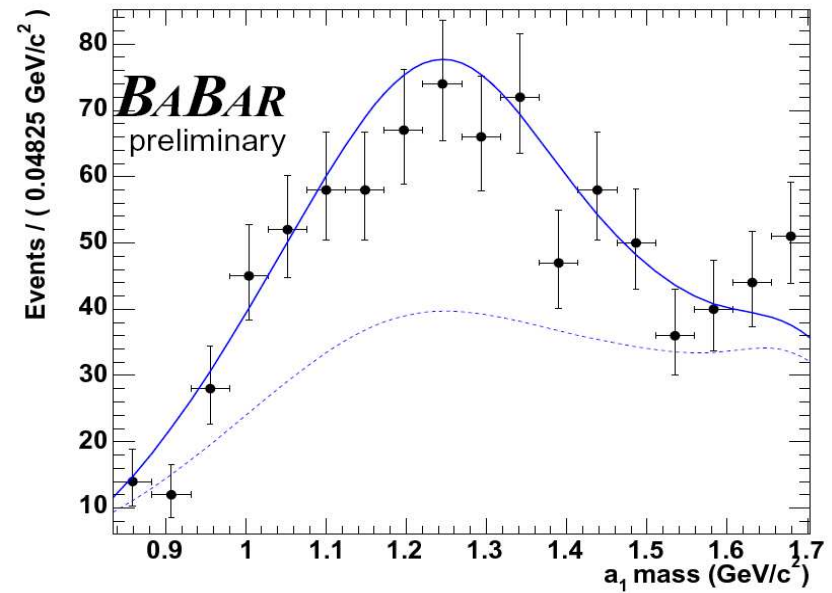
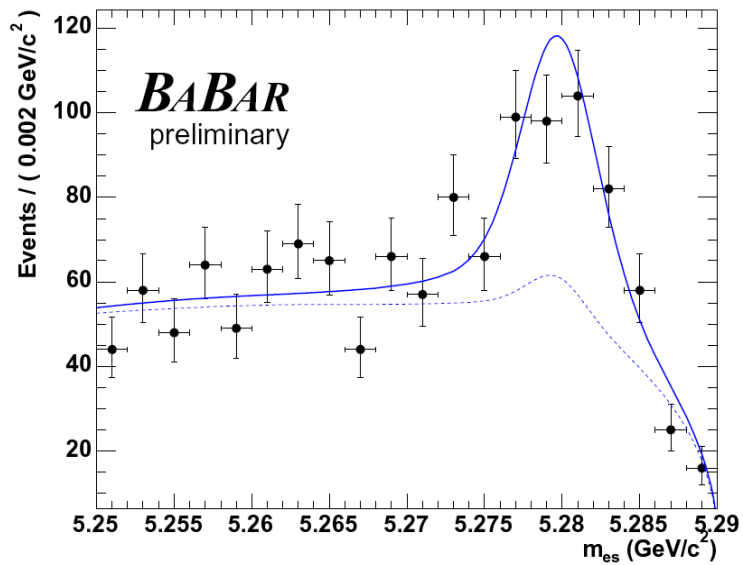



$K^{*0}\rho^+$

- M/Beneke *et al.* hep-ph/0604005
- assuming SU(3) symmetry
- $\alpha = 90 \pm 7^{+2}_{-5}$